

# Repair Parts MANUAL

---

1.0 Liter (MA10)  
1.2 Liter (MA12)

## GAS/GASOLINE ENGINE

# GENERAC

---

*P. O. Box 8*  
*PHONE: (414) 544-4811*

*Waukesha, WI 53187*  
*FAX: (414) 544-4851*

---

# Table of Contents

<b>Quick Reference Parts Guide .....</b>	<b>Page 1</b>
<b>Cylinder Block &amp; Oil Pan .....</b>	<b>Page 2, 3</b>
<b>Distributor .....</b>	<b>Page 4, 5</b>
<b>Engine Common Parts .....</b>	<b>Page 6, 7</b>
<b>Pistons and Crankshaft .....</b>	<b>Page 8</b>
<b>Oil Pump .....</b>	<b>Page 9</b>
<b>Cylinder Head &amp; Rocker Cover .....</b>	<b>Page 10</b>
<b>Camshaft &amp; Valve Mechanism.....</b>	<b>Page 11</b>

# QUICKREFERENCE PARTS GUIDE

## Tune-Up Parts

DESCRIPTION	PART NO.	QTY
Air Cleaner (Gasoline Carburetor)	71838	1
Air Cleaner	73912	1
Oil Filter	75755	1
V-Belt	79173	1
Spark Plugs (1.0 Liter)	998-69828	4
Spark Plugs (1.2 Liter)	147-70965	4
Fuel Filter	74016	1
Thermostat	503-69828	1
Distributor Cap	315-69828	1
Distributor Rotor	314-69828	1
Distributor Points	320-69828	1

## Engine Parts

DESCRIPTION	PART NO.	QTY
Rear Main Seal (1.0 Liter)	130-69828	1
Rear Main Seal (1.2 Liter)	106-70965	1
Main Bearing Upper (STD)	219-69828	5
Bushing Lower (STD)	220-69828	5
Connecting Rod Bearing (STD)	213-69828	8
Camshaft Oil Seal (Front)	116-69828	1
Crankshaft Seal (Front)	116-69828	1
Piston w/Pin (STD)-(MA10)	210-69828	4
Piston w/Pin (STD)-(MA12)	117-70965	4
Piston Rings (STD)-(MA10)	123-70965	4
Piston Rings (STD)-(MA12)	333-69828	4
Rocker Cover Gasket	171-70965	1
Timing Belt (MA10)	135-70965	1
Timing Belt (MA12)	187-69828	1

# CYLINDER BLOCK & OIL PAN

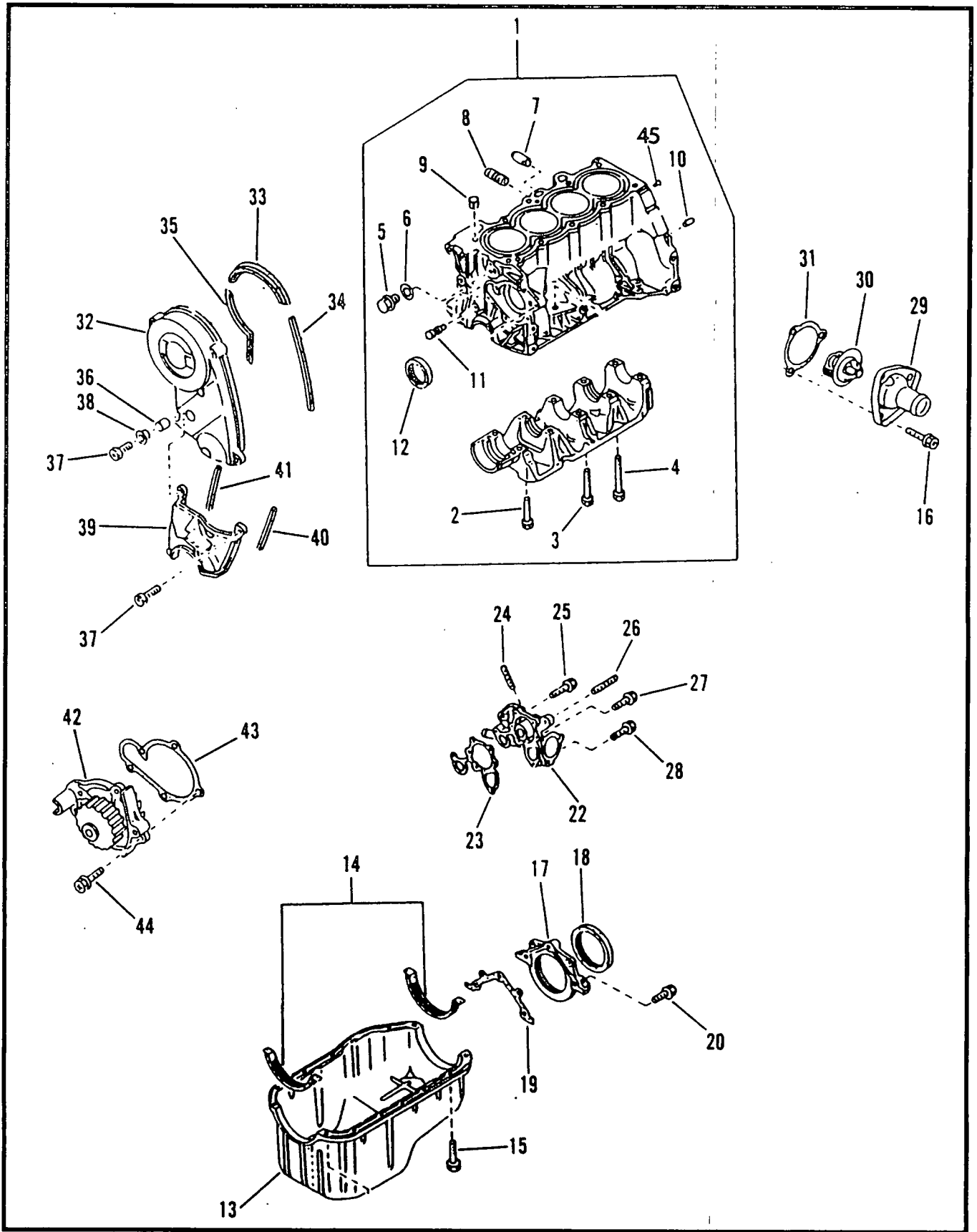

# CYLINDER BLOCK & OIL PAN

ITEM	PART NO.	QTY	DESCRIPTION
1	100-70965	1	Cylinder Block (MA12)
	100-69828	1	Cylinder Block (MA10)
2	101-69828	1	Bolt, Main Bearing Cap
3	102-69828	1	Bolt, Main Bearing Cap
4	103-69828	8	Bolt, Main Bearing Cap
5	104-69828	2	Plug, Oil Gallery
6	105-69828	2	Gasket, Oil Gallery Plug
7	106-69828	1	Valve, Oil Pressure Regulator
8	101-70965	1	Stud, Oil Filter (MA12)
	107-69828	1	Stud, Oil Filter (MA10)
9	111-69828	2	Welch Plug
10	112-69828	2	Dowel Pin (MA10)
	112-70965	2	Dowel Pin (MA12)
11	113-69828	1	Welch Plug
12	116-69828	1	Oil Seal, Crankshaft (Front)
13	117-69828	1	Oil Pan
14	120-69828	1	Gasket Set, Oil Pan
15	123-69828	14	Bolt
16	504-69828	3	Screw, Water Pump
17	129-69828	1	Retainer, Oil Seal (Rear)-(MA10)
	105-70965	1	Retainer, Oil Seal (Rear)-(MA12)
18	106-70965	1	Oil Seal, Crankshaft (Rear)-(MA12)
	130-69828	1	Oil Seal, Crankshaft (Rear)-(MA10)
19	107-70965	1	Gasket, Retainer (MA12)
	131-69828	1	Gasket, Retainer (MA10)
20	132-69828	3	Screw
22	133-69828	1	Thermostat Housing
23	140-69828	1	Gasket, Thermostat Housing
24	134-69828	2	Stud
25	126-69828	1	Bolt
26	135-69828	1	Stud
27	124-69828	3	Bolt
28	125-69828	1	Bolt
29	505-69828	1	Water Outlet
30	503-69828	1	Thermostat
31	506-69828	1	Gasket, Water Outlet
32	148-70965	1	Dust Cover (Upper)
33	149-70965	1	Gasket, Cover
34	150-70965	1	Gasket, Cover
35	150-70965	1	Gasket, Cover
36	142-70965	5	Collar, Front Cover (MA12)
	150-69828	5	Collar, Front Cover (MA10)
37	145-69828	7	Bolt
38	143-70965	6	Grommet, Front Cover (MA12)
	245-69828	6	Grommet, Front Cover (MA10)
39	139-70965	1	Cover (Front)- (MA12)
	141-69828	1	Cover (Front)- (MA10)
40	150-69828	1	Gasket, Dust Cover (Lower)
41	144-69828	1	Gasket, Front Cover
42	146-70965	1	Water Pump Assembly (MA12)
	326-69828	1	Water Pump Assembly (MA10)
43	501-69828	1	Gasket
44	502-69828	5	Screw, Water Pump
45	102-70965	1	Welch Plug
	70965	1	Engine Assembly (MA12)
	69828	1	Engine Assembly (MA10)

# DISTRIBUTOR

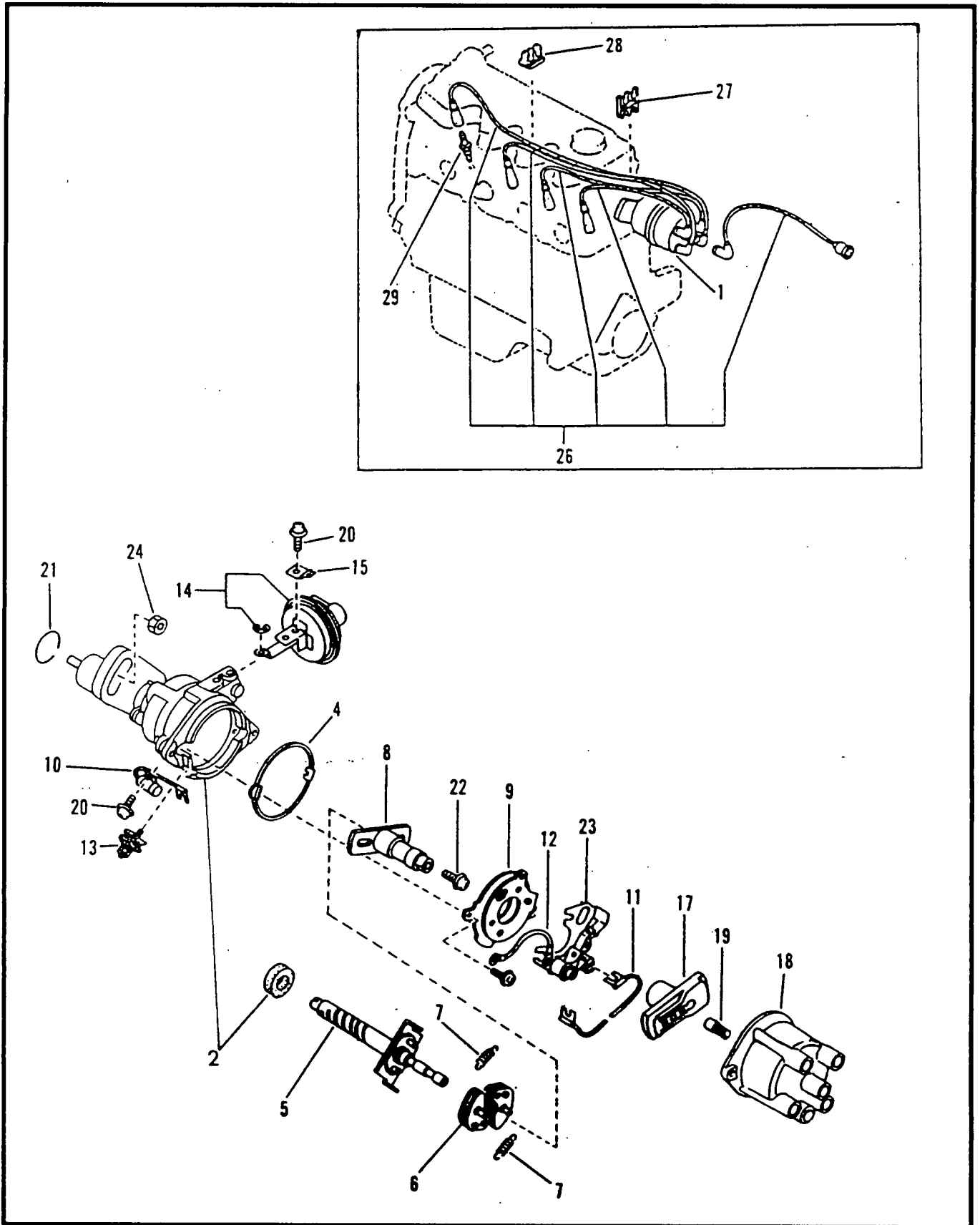

# DISTRIBUTOR

ITEM	PART NO.	QTY	DESCRIPTION
1	298-69828	1	Distributor Assembly
2	299-69828	1	Distributor Housing
4	301-69828	1	Clamp, Kit
5	302-69828	1	Shaft
6	303-69828	2	Weight
7	304-69828	2	Spring
8	305-69828	1	Cam Set
9	306-69828	1	Plate
10	307-69828	1	Condensor
11	308-69828	1	Lead Wire
12	309-69828	1	Ground Wire
13	310-69828	1	Terminal
14	311-69828	1	Vacuum Control
15	312-69828	1	Ground Terminal
17	314-69828	1	Rotor
18	315-69828	1	Cap
19	316-69828	1	Point
20	317-69828	1	Screw Kit
21	318-69828	1	O-Ring
22	319-69828	3	Screw
23	320-69828	1	Contact Set
24	321-69828	1	Nut
26	355-69828	1	High Tension Cable Set
27	361-69828	1	Clamp
28	362-69828	1	Clamp
29	296-69828	4	Spark Plug

# ENGINE COMMON PARTS

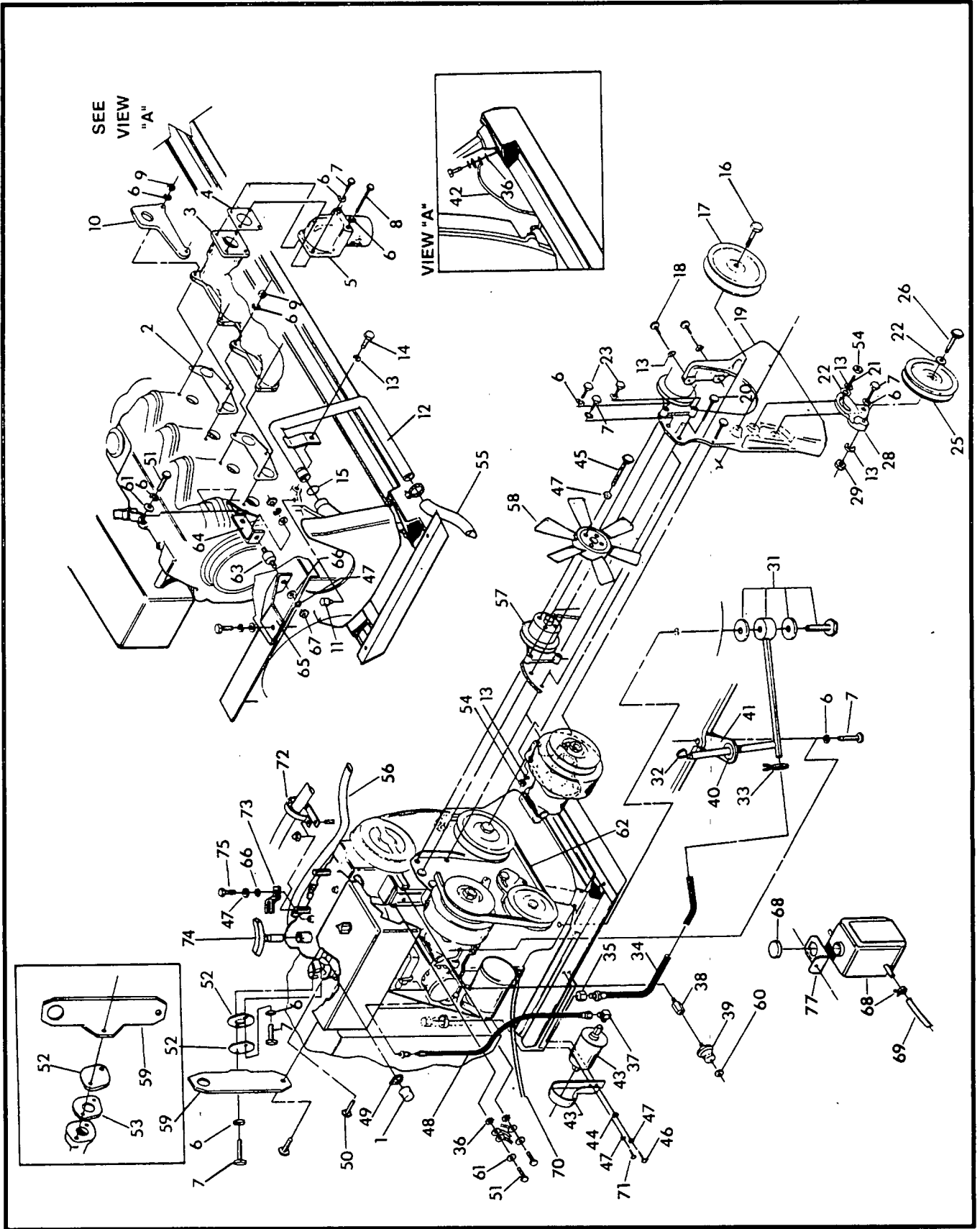

# ENGINE COMMON PARTS

ITEM	PART NO.	QTY	DESCRIPTION	ITEM	PART NO.	QTY	DESCRIPTION
1	69943	2	Rubber Cap- 5/8" ID	37	70925	1	90° Elbow
2	70968	1	Exhaust Manifold Gasket	38	42574	1	Adapter- 1/8" NPTF x 1/8"
3	75533	1	Exhaust Manifold	39	60108	1	Oil Pressure Switch
4	75674	1	Gasket- Exhaust Manifold to Exhaust Elbow	40	75770	1	Grommet- 3/8" ID
5	62798	1	Exhaust Elbow	41	74838	1	Dipstick Tube Bracket
6	72545	19	Lockwasher- M8	42	75778	1	Ground Wire - No. 10
7	72586	7	Hex Head Screw M8-1.25 x 25mm	43	74024	1	Fuel Pump
8	72541	2	Hex Head Screw M8-1.25 x 90mm	44	74043	1	Ext. Lockwasher- M6
9	72540	6	Hex Nut- M8-1.25	45	75213	4	Hex Head Screw M6-1.00 x 16mm
10	72524	1	Lifting Lug	46	70001	2	Hex Head Screw M6-1.00 x 20mm
11	75732	1	Plug	47	70005	6	Lockwasher- M6
12	74854	1	Suction Tube Assembly	48	69861	1	Fuel Line
13	74008	7	Lockwasher- M10	49	69855	1	Clamp
14	74003	1	Hex Head Screw M10-1.50 x 15mm	50	69877	1	Hex Head Screw M12-1.25 x 15mm
15	70989	1	O-Ring	51	74045	4	Hex Head Screw M8-1.25 x 16mm
16	71845	1	Engine Crankshaft Pulley	52	59511	1	Cover
17	71845	1	Engine Crankshaft Pulley	53	74053	1	Gasket
18	74004	2	Hex Head Screw M10-1.50 x 30mm	54	74009	3	Hex Nut- M10-1.50
19	75544	1	Engine Mount	55	74097	1	Lower Radiator Hose
20	74005	2	Hex Head Screw M10-1.50 x 55mm	56	72598	1	Upper Radiator Hose
21	74047	1	Stud- M10-1.50 x 75mm	57	76048	1	Fan Pulley Assembly
22	74007	1	Flatwasher- M10	58	75614	1	Fan
23	72554	2	Hex Head Screw M8-1.25 x 40mm	59	78862	1	Rear Lifting Lug
25	43604	1	Idler Pulley	60	22207	1	Brass Nut- No. 8-32
26	31578	1	Hex Head Screw 3/8"-16 x 1-1/2"	61	74013	2	Flatwasher- M8
28	74836-A	1	Idler Pulley Bracket	62	43776	1	Fan Belt
29	22241	1	Hex Nut- 3/8"-16	63	27831	1	Vibration Dampener
31	74898	1	Dipstick Tube	64	74859	1	Bracket- Eng. to Vib. Damp.
32	75735	1	Dipstick	65	74860	1	Bracket- Vib. Damp. to Rad.
33	70928	1	Clamp	66	70007	2	Flatwasher- M6
34	69860-A	1	Oil Drain Tube	67	74034	2	Nut- 1/4"-20
35	69811	1	Cap- 1/4" NPT	68	61690	1	Coolant Recovery Bottle
36	74044	3	Ext. Lockwasher- M8	69	29032	1	Hose- 4 feet
				70	74060-A	1	Starter Cable
				71	71944	1	Hex Head Screw- M6 x 25
				72	55934-U	1	Clamp

# PISTONS AND CRANKSHAFT

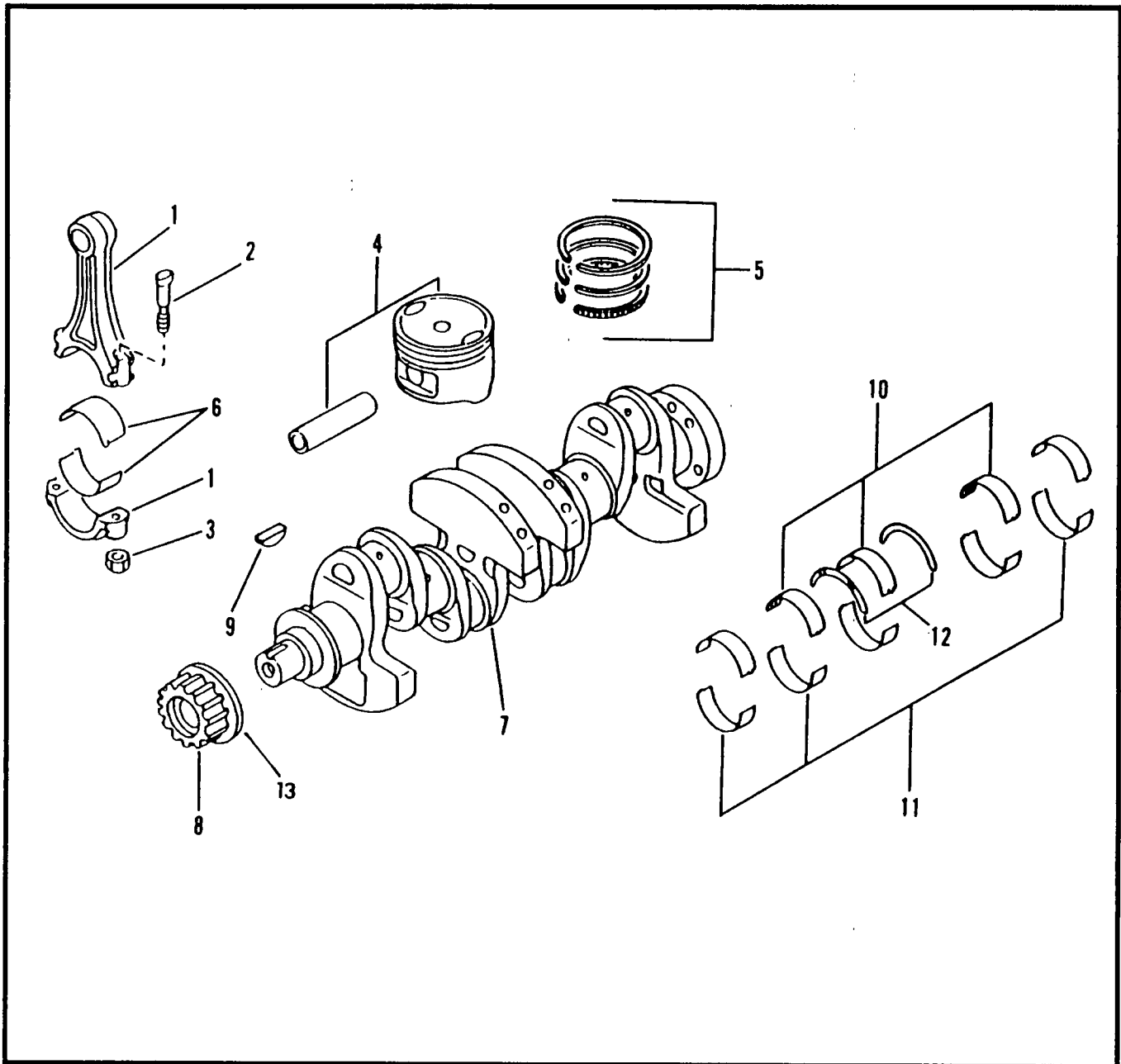

ITEM	PART NO.	QTY	DESCRIPTION	ITEM	PART NO.	QTY	DESCRIPTION
1	115-70965	4	Connecting Rod (MA12)	6	213-69828	8	Connecting Rod Bearing
	207-69828	4	Connecting Rod (MA10)	7	125-70965	1	Crankshaft (MA12)
2	116-70965	8	Bolt (MA12)		214-69828	1	Crankshaft (MA10)
	208-69828	8	Bolt (MA10)	8	126-70965	1	Sprocket (MA12)
3	209-69828	8	Nut		215-69828	1	Sprocket (MA10)
4	117-70965	4	Piston w/Pin (STD)-(MA12)	9	216-69828	1	Crankshaft Key (MA12)
	210-69828	4	Piston w/Pin (STD)-(MA12)		216-69828	1	Crankshaft Key (MA10)
	118-70965	4	Piston w/Pin (0.02mm OS)-(MA12)	10	219-69828	5	Upper Bearing (STD)
	211-69828	4	Piston w/Pin (0.02 mm os)-(MA10)		223-69828	5	Upper Bearing (0.25mm US)
5	123-70965	4	Piston Ring (STD)-(MA12)	11	220-69828	5	Lower Bushing (STD)
	333-69828	4	Piston Ring (STD)-(MA10)		224-69828	5	Lower Bushing (0.25mm US)
	124-70965	4	Piston Ring (0.02mm OS)	12	129-70965	2	Upper Thrust Washer
				13	127-70965	1	Sprocket Plate

# OIL PUMP

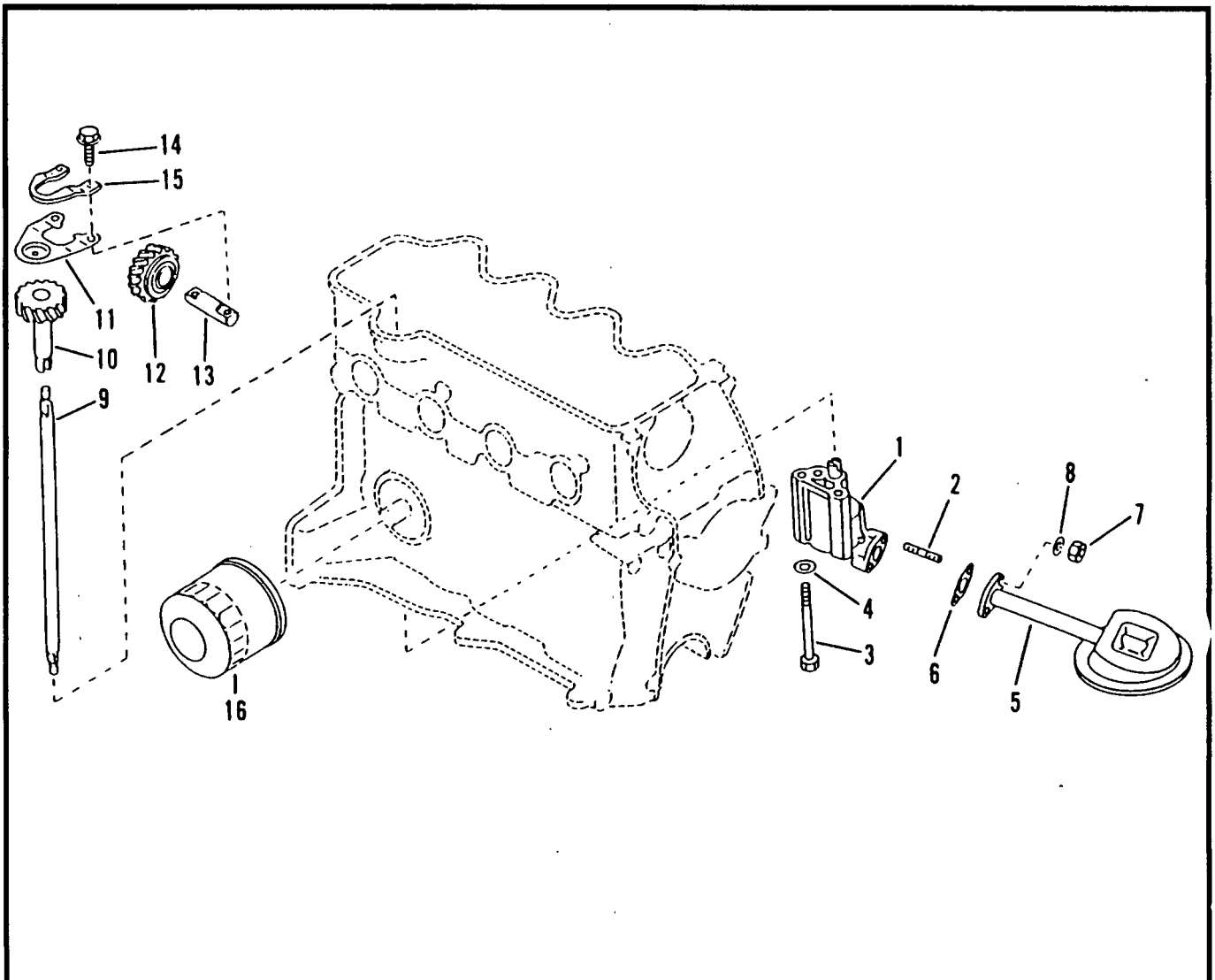

ITEM	PART NO.	QTY	DESCRIPTION
1	229-69828	1	Oil Pump Assembly
2	230-69828	2	Stud
3	231-69828	2	Bolt
4	232-69828	2	Washer
5	233-69828	1	Oil Strainer
6	234-69828	1	Oil Strainer Gasket
7	235-69828	2	Nut
8	128-69828	2	Lockwasher
9	144-70965	1	Pump Drive Spindle (MA12)
	236-69828	1	Pump Drive Spindle (MA10)
10	237-69828	1	Drive Gear
11	238-69828	1	Oil Regulator Spring
12	239-69828	1	Idler Gear
13	240-69828	1	Idler Gear Shaft
14	241-69828	2	Bolt
15	145-70965	1	Spindle Support
16	75755	1	Oil Filter

# CYLINDER HEAD & ROCKER COVER

ITEM	PART NO.	QTY	DESCRIPTION	ITEM	PART NO.	QTY	DESCRIPTION
1	109-70965	1	Cylinder Head Assy. (MA12)	17	166-69828	5	Cylinder Head Bolt (Short)
	151-69828	1	Cylinder Head Assy. (MA10)	18	113-70965	1	Cylinder Head Gasket (MA12)
2	152-69828	1	Plug		168-69828	1	Cylinder Head Gasket (MA10)
3	153-69828	1	Plug	19	169-69828	2	Connector Cap
4	116-69828	1	Oil Seal	20	170-69828	2	Hose Clamp
5	155-69828	1	Plug	21	171-69828	1	Rocker Valve Cover
6	156-69828	6	Stud	22	114-70965	1	Rocker Cover Gasket
7	111-70965	4	Exhaust Valve Guide (MA12)	23	175-69828	1	Oil Filler Cap
	162-69828	4	Exhaust Valve Guide (MA10)	24	172-69828	2	Rocker Cover Cap
8	110-70965	4	Intake Valve Guide (MA12)	25	174-69828	2	Nut
	163-69828	4	Intake Valve Guide (MA10)	26	112-70965	1	Dowel Pin
9	154-69828	2	Plug				
10	159-69828	1	Stud				
11	157-69828	1	Stud				
12		1	Screw - M8-1.25 x 20mm				
13	161-69828	1	Exhaust Valve Seat				
14	160-69828	8	Intake Valve Seat				
15	164-69828	5	Cylinder Head Bolt (Long)				
16	167-69828	10	Washer				

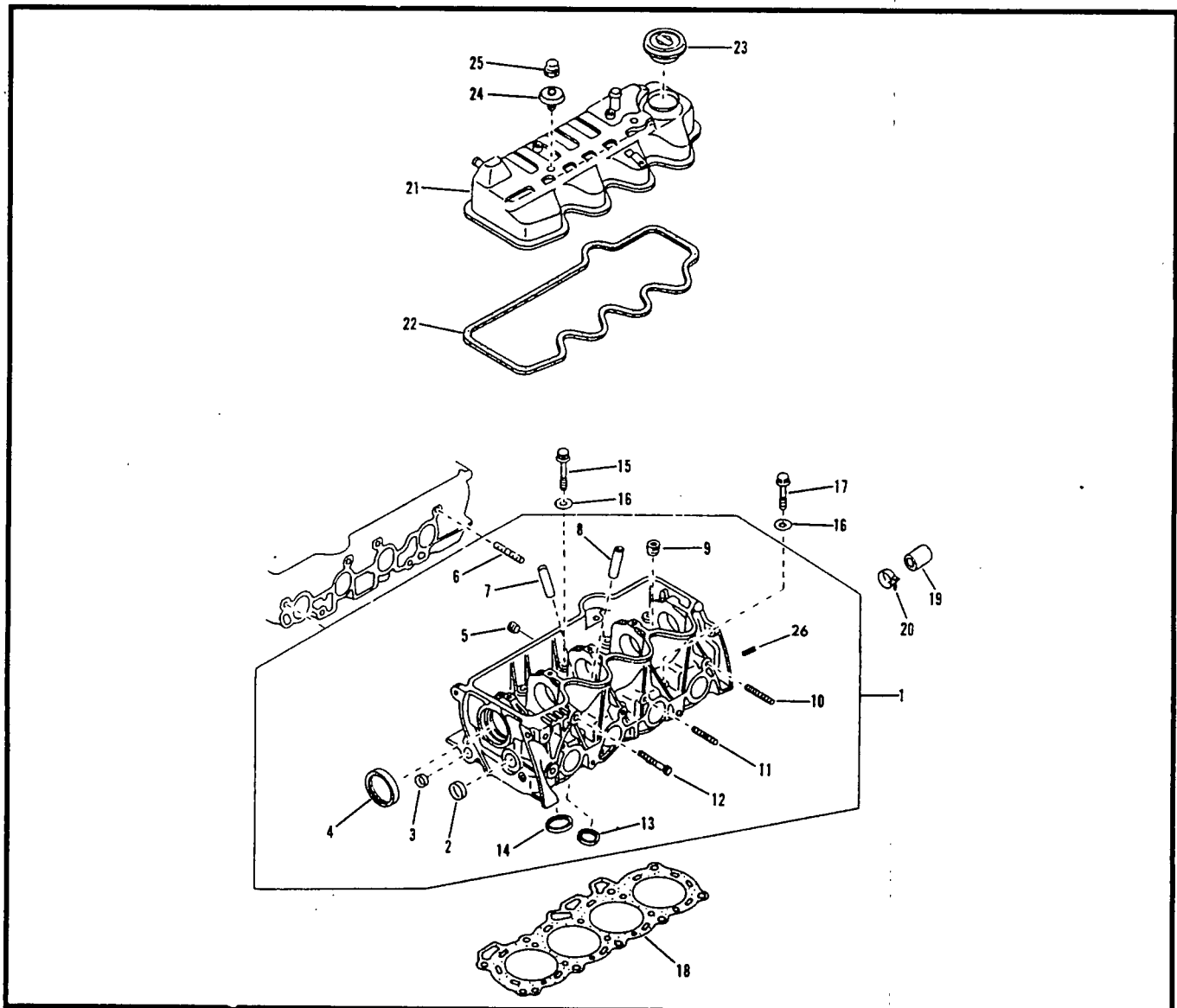

# CAMSHAFT & VALVE MECHANISM

ITEM	PART NO.	QTY	DESCRIPTION	ITEM	PART NO.	QTY	DESCRIPTION
1	130-70965	1	Camshaft Assy. (MA12)	13	135-70965	1	Timing Belt (MA12)
	176-69828	1	Camshaft Assy. (MA10)	14	137-70965	4	Intake Valve (MA12)
2	177-69828	1	Camshaft Plug	15	138-70965	4	Intake Valve (MA10)
3	178-69828	1	Camshaft Key	16	188-69828	4	Exhaust Valve (MA12)
4		4	Dowel Pin	17	189-69828	4	Exhaust Valve (MA10)
5	179-69828	1	Retainer	18	190-69828	8	Outer Valve Spring
6	131-70965	2	Camshaft Sprocket (MA12)	19	191-69828	8	Valve Spring Seat (Outer)
	180-69828	2	Camshaft Sprocket (MA10)	20	192-69828	8	Valve Spring retainer
7	181-69828	3	Camshaft Sprocket Bolt	21	193-69828	16	Valve Spring Key
8	182-69828	1	Tab Washer	22	194-69828	8	Valve Oil Seal
9	132-70965	1	Belt Tensioner	23	195-69828	1	Rocker Shaft
10	133-70965	1	Tensioner Spring	24	196-69828	2	Plug
11	185-69828	1	Lockwasher	25	197-69828	2	Rocker Spring
12	134-70965	1	Nut	26	198-69828	2	Rocker Retainer
				27	199-69828	1	Rocker Retainer
				28	200-69828	2	Rocker Shaft Stud
				29	201-69828	3	Rocker Shaft Bracket
				30	202-69828	3	Washer
				31	203-69828	2	Bolt
				32	204-69828	8	Valve Rocker
					205-69828	8	Rocker Shaft Stud
					206-69828	8	Rocker Stud Nut

