

PB16000G

GENERAC
One-Stop Service

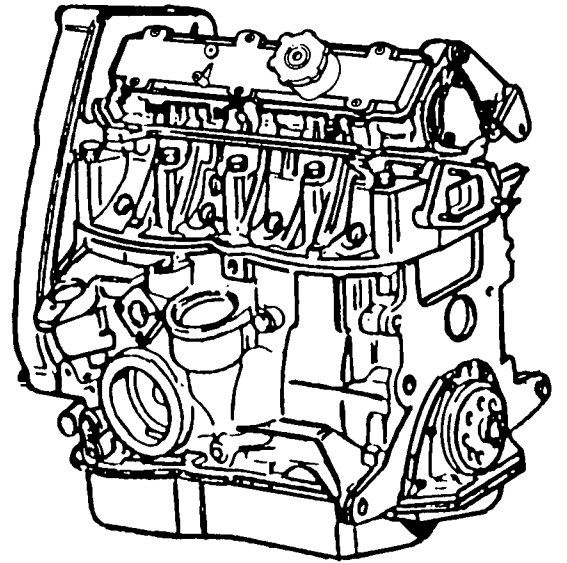

1.6

GAS

PARTS
MANUAL

P.O. BOX 8 WAUKESHA WI. 53187

PHONE: (414) 544-4811 / FAX: (414) 544-0179

PRINTED IN U.S.A.

ISSUED: 08/26/96

TABLE OF CONTENTS

ENGINE SERVICE RECOMMENDATIONS	2
ENGINE GASKETS, TUNE UP PARTS, TORQUE SPECIFICATIONS	3
CYLINDER BLOCK	4
CYLINDER HEAD	5
VALVE COVER / CAMSHAFT HOUSING	6
FRONT ENGINE SEALS / COVERS	7
REAR ENGINE SEALS / COVERS	8
OIL PAN	9
CRANKSHAFT	10
PISTONS AND RELATED COMPONENTS	11
TIMING BELT AND GEARS	12
TIMING BELT SHROUD	13
VALVE TRAIN	14
VALVE SHIMS	15
OIL PUMP AND FILTER	16
COOLING SYSTEM	17
ENGINE BREATHER	18
IGNITION SYSTEM	19
FUEL SYSTEM (NAT. GAS / LP VAPOR)	20-21
FUEL SYSTEM (NAT. GAS)	22-23
FUEL SYSTEM (LP LIQUID CARBURETOR)	24-25
ENGINE FINISH PARTS (MECHANICAL GOVERNOR UNITS)	26-27
ENGINE FINISH PARTS (ELECTRONIC GOVERNOR UNITS)	28-29
ELECTRONIC GOVERNOR	30

LEGEND

"AR" AS REQUIRED

(STD) STANDARD SIZE

"O/S" OVERSIZE

"U/S" UNDERSIZE

ENGINE SERVICE RECOMMENDATIONS

SPECIFICATIONS:

CRANKCASE OIL CAPACITY: 4.5 U.S. QUARTS
COOLING SYSTEM CAPACITY: 2 U.S. GALLONS

RECOMMENDED FLUIDS:

COOLANT: USE A MIXTURE OF HALF LOW SILICATE , ETHYLENE GLYCOL BASE ANTI-FREEZE AND HALF SOFT WATER. COOLING SYSTEM CAPACITY IS ABOUT 2 U.S. GALLONS (8.5 LITERS). USE ONLY SOFT WATER AND ONLY LOW SILICATE ANTI-FREEZE. IF DESIRED, YOU MAY ADD A HIGH QUALITY RUST INHIBITOR TO THE RECOMMENDED COOLANT MIXTURE. WHEN ADDING COOLANT, ALWAYS ADD THE RECOMMENDED 50-50 MIXTURE.

ENGINE OIL: THE UNIT HAS BEEN FILLED WITH 15W-40 ENGINE OIL CLASSIFIED "FOR SERVICE SC, SD, SE OR SF" AT THE FACTORY. DETERGENT OILS KEEP THE ENGINE CLEANER AND REDUCE CARBON DEPOSITS. USE OIL HAVING THE FOLLOWING SAE VISCOSITY RATING, BASED ON THE AMBIENT TEMPERATURE RANGE ANTICIPATED BEFORE THE NEXT OIL CHANGE:

TEMPERATURE	RECOMMENDED OIL GRADE
ABOVE 86°F	SAE 40
32° TO 85°F	SAE 30
BELOW 32°F	SAE 20W
ALL SEASONS	SAE 10W-30

PERIODIC MAINTENANCE SCHEDULE:

EVERY THREE MONTHS

CHECK BATTERY
INSPECT FUEL SYSTEM
CHECK EXHAUST SYSTEM FOR LEAKS
CHECK IGNITION SYSTEM
CHECK FAN BELT

EVERY SIX MONTHS

TEST ENGINE SAFETY DEVICES

ONCE ANNUALLY

TEST ENGINE GOVERNOR; ADJUST OR REPAIR
FLUSH COOLING SYSTEM

ONCE EVERY 100 OPERATING HOURS

CHANGE ENGINE OIL
CHANGE OIL FILTER

ONCE EVERY 200 OPERATING HOURS

CHANGE AIR CLEANER

ONCE EVERY 500 OPERATING HOURS

CHECK VALVE CLEARANCE
CHECK IGNITION SYSTEM
CHECK ENGINE DC ALTERNATOR

ENGINE GASKETS, TUNE-UP PARTS, TORQUE SPECS

DESCRIPTION	GENERAC #	QTY
HEAD GASKET	101-97390	1
VALVE COVER GASKET	118-97390	1
CAMSHAFT HOUSING GASKET	126-97390	1
FRONT WATER JACKET COVER GASKET	135-97390	1
FRONT MAIN OIL SEAL RETAINER GASKET	139-97390	1
FRONT MAIN OIL SEAL	143-97390	1
OIL PUMP DRIVE SHAFT SEAL	145-97390	1
OIL PUMP DRIVE SHAFT SEAL RETAINER GASKET	148-97390	1
REAR WATER JACKET COVER GASKET	154-97390	1
REAR MAIN OIL SEAL	153-97390	1
REAR MAIN OIL SEAL RETAINER GASKET	150-97390	1
OIL PAN GASKET	160-97390	1
CAMSHAFT OIL SEAL	145-97390	1
WATER PUMP GASKET	261-97390	1
THERMOSTAT GASKET	98907	1
WATER TUBE GASKET	99478	1
VALVE SEAL	211-97390	8

ENGINE TUNE-UP / ENGINE PARTS	
OIL FILTER	99021
AIR FILTER ELEMENT	73912
SPARK PLUGS (BOSCH)	WR6DC
SPARK PLUGS (CHAMPION)	RN9YC
IGNITION COIL	72557
IGNITION COIL WIRE	98852
BELT, FAN (1800 RPM)	20621
BELT, FAN (3600 RPM)	20439
BELT, WATER PUMP	75130
PISTON (STD)	(SEE PG. 11)
PIN, PISTON	169-97390
LOCK RING, PISTON PIN	177-97390
PISTON RINGS (STD)	179-97390
REAR MAIN OIL SEAL	153-97390
CRANKSHAFT MAIN BEARING (STD)	164-97390
ROD BEARING (STD)	170-97390

TORQUE SPECIFICATIONS	
MAIN BEARING CAP BOLTS	59 ft lbs
CYLINDER HEAD BOLT (M10)	29.5 ft lbs
CYLINDER HEAD BOLT (M8)	22 ft lbs
CAMSHAFT HOUSING BOLT	15 ft lbs
ENGINE BREATHER BOLT	17 ft lbs
INTAKE / EXHAUST MANIFOLD NUT	20.5 ft lbs
CON ROD NUT	37.5 ft lbs
FLYWHEEL BOLT	62 ft lbs
CAMSHAFT DRIVE GEAR BOLT	62 ft lbs
TIMING BELT TENSIONER NUT	32.5 ft lbs
OIL PUMP SHAFT DRIVE GEAR	62 ft lbs
SPARK PLUGS	27 ft lbs

Cylinder Block

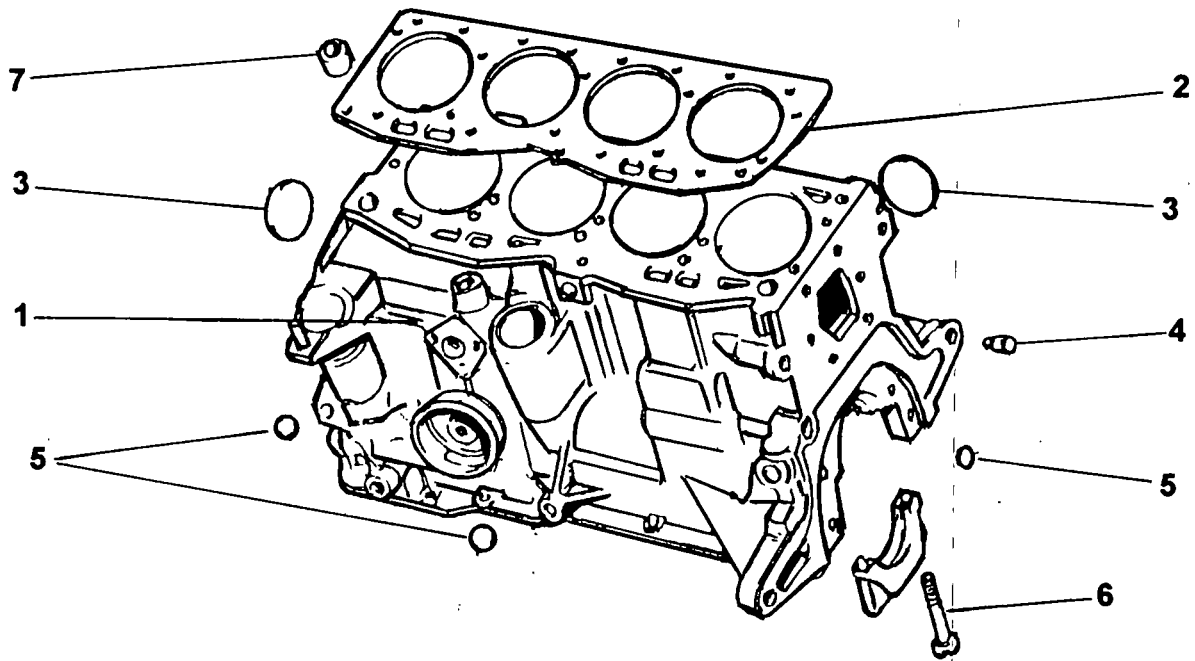

REF #	GENERAC #	DESCRIPTION	QTY
1	100-97390	CYLINDER BLOCK	1
2	101-97390	HEAD GASKET	1
3	102-97390	PLUG	2
4	103-97390	DOWEL	1
5	104-97390	PLUG	3
6	105-97390	SCREW	4
7	106-97390	BUSHING	2

CYLINDER HEAD

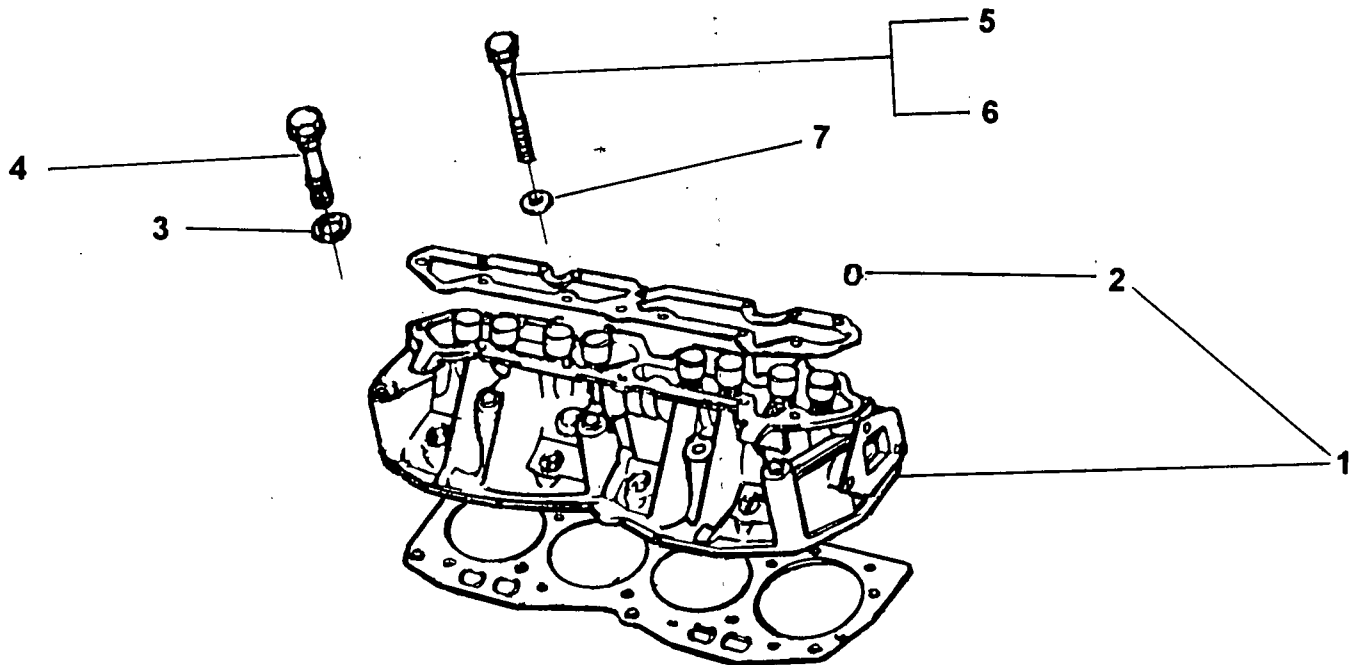

REF #	GENERAC #	DESCRIPTION	QTY
1	107-97390	CYLINDER HEAD	1
2	108-97390	PLUG	2
3	110-97390	WASHER	6
4	111-97390	SCREW	4
5	113-97390	SCREW	4
6	116-97390	SCREW	4
7	117-97390	WASHER	4

VALVE COVER / CAMSHAFT HOUSING

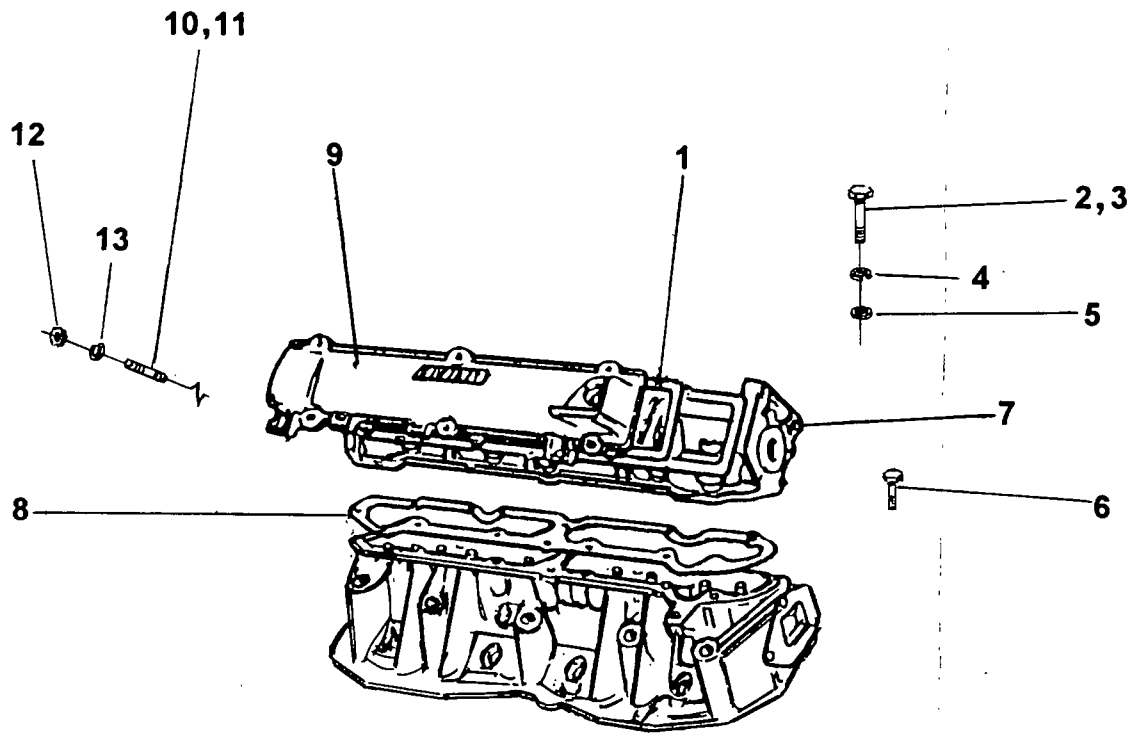

REF #	GENERAC #	DESCRIPTION	QTY
1	118-97390	GASKET, VALVE COVER	1
2	119-97390	SCREW	4
3	120-97390	SCREW	4
4	121-97390	WASHER	4
5	122-97390	WASHER	4
6	123-97390	SCREW	4
7	124-97390	CAMSHAFT HOUSING	1
8	126-97390	GASKET, CAMSHAFT HOUSING	1
9	127-97390	VALVE COVER	1
10	128-97390	STUD	4
11	129-97390	STUD	4
12	130-97390	NUT	4
13	131-97390	WASHER	3

FRONT ENGINE SEALS / COVERS

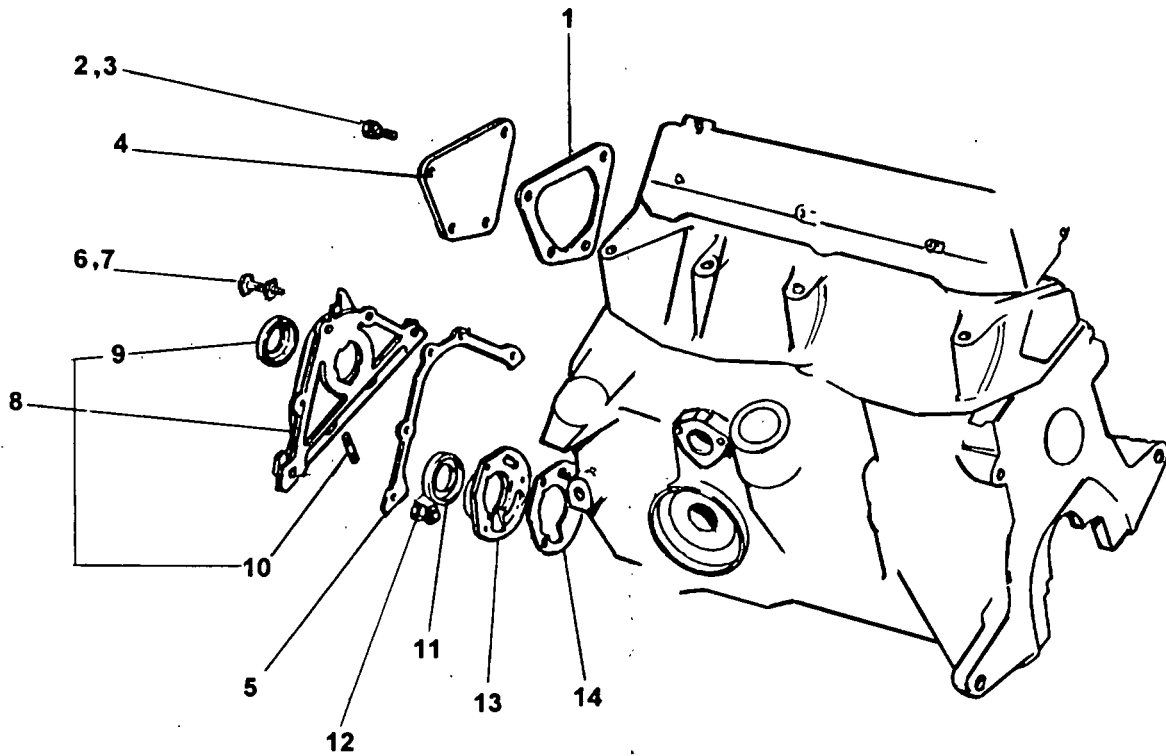

REF #	GENERAC #	DESCRIPTION	QTY
1	135-97390	FRONT WATER JACKET COVER GASKET	1
2	136-97390	SCREW	4
3	137-97390	SCREW AND WASHER	4
4	138-97390	FRONT WATER JACKET COVER	1
5	139-97390	FRONT MAIN OIL SEAL RETAINER GASKET	1
6	140-97390	SCREW AND WASHER	5
7	141-97390	SCREW AND WASHER	5
8	142-97390	FRONT MAIN OIL SEAL RETAINER	1
9	143-97390	FRONT MAIN OIL SEAL	1
10	144-97390	STUD	2
11	145-97390	OIL PUMP DRIVE SHAFT OIL SEAL	1
12	146-97390	SCREW AND WASHER	2
13	147-97390	COVER	1
14	148-97390	OIL PUMP DRIVE SHAFT COVER GASKET	1

REAR ENGINE SEALS / COVERS

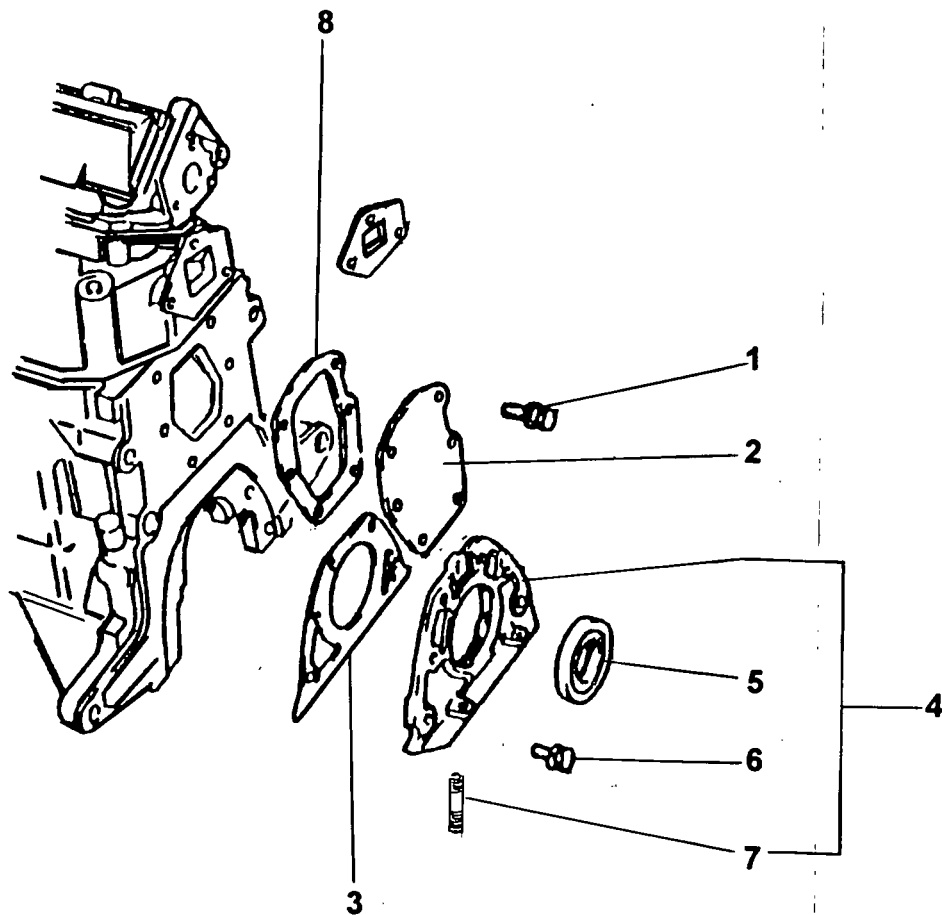

REF #	GENERAC #	DESCRIPTION	QTY
1	146-97390	SCREW AND WASHER	2
2	149-97390	REAR WATER JACKET COVER	1
3	150-97390	REAR MAIN OIL SEAL RETAINER GASKET	1
4	152-97390	REAR MAIN OIL SEAL RETAINER	1
5	153-97390	REAR MAIN OIL SEAL	1
6	144-97390	STUD	2
7	140-97390	SCREW AND WASHER	5
8	154-97390	REAR WATER JACKET COVER GASKET	1

OIL PAN

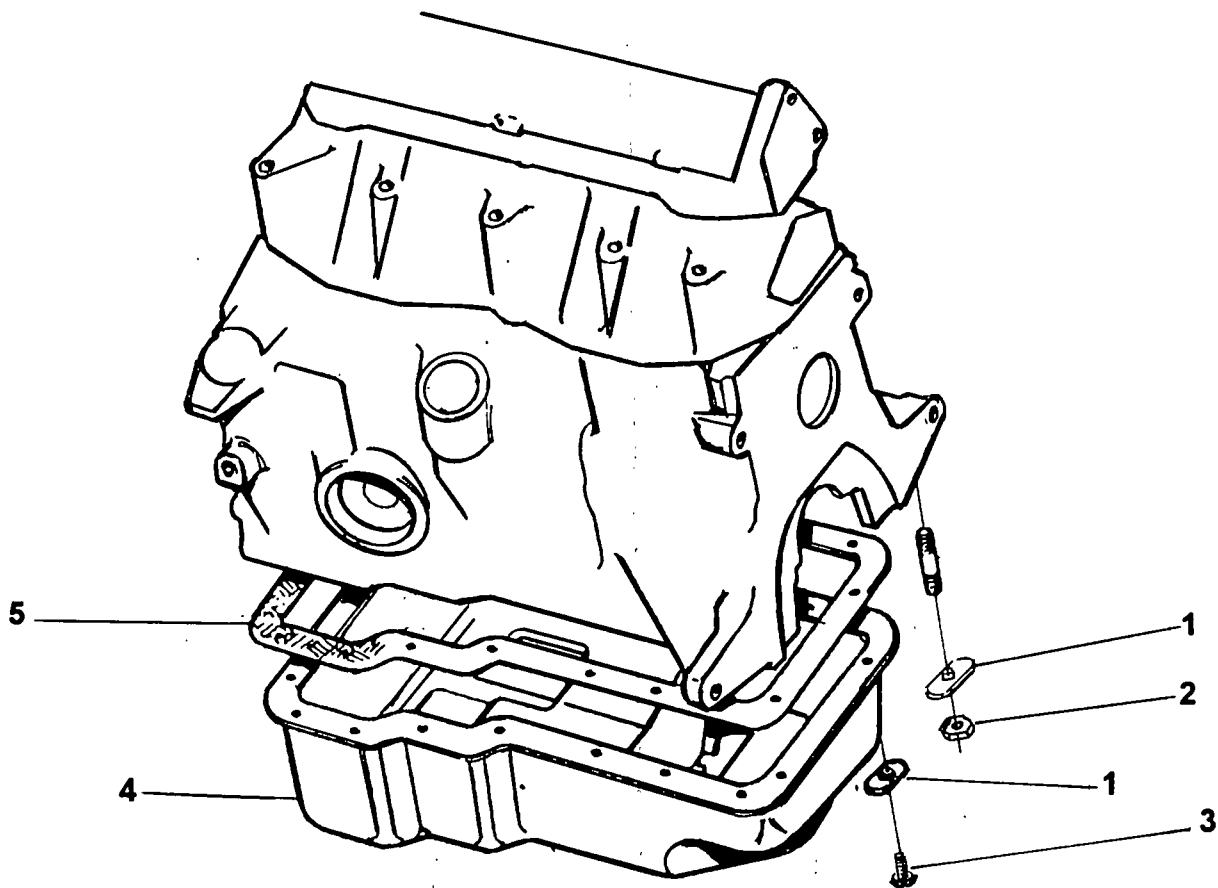

REF #	GENERAC #	DESCRIPTION	QTY
1	155-97390	LOCK WASHER	16
2	130-97390	NUT	6
3	156-97390	SCREW	8
4	158-97390	OIL PAN	1
5	160-97390	GASKET, OIL PAN	1

CRANKSHAFT

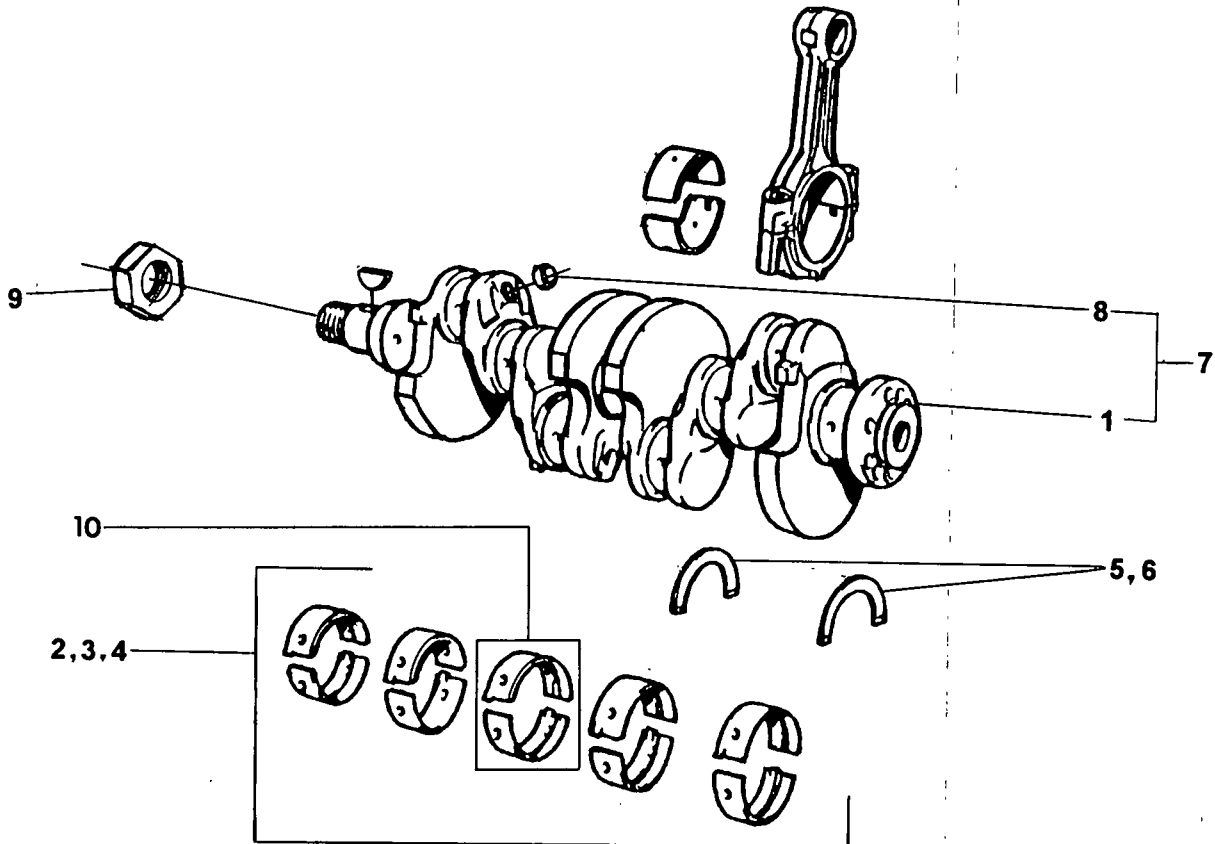

REF #	GENERAC #	DESCRIPTION	QTY
1	161-97390	CRANKSHAFT	1
2	162-97390	MAIN BEARING (0.20 mm U/S)	AR
3	163-97390	MAIN BEARING (0.10 mm U/S)	AR
4	164-97390	MAIN BEARING (STD)	4
5	165-97390	THRUST BEARING (STD)	4
6	166-97390	THRUST BEARING (0.5 mm U/S)	AR
7	167-97390	CRANKSHAFT ASS'Y	1
8	168-97390	DOWEL	1
9	273-97390	CRANKSHAFT NUT	1
10		CENTER MAIN BEARING	1

PISTONS AND RELATED COMPONENTS

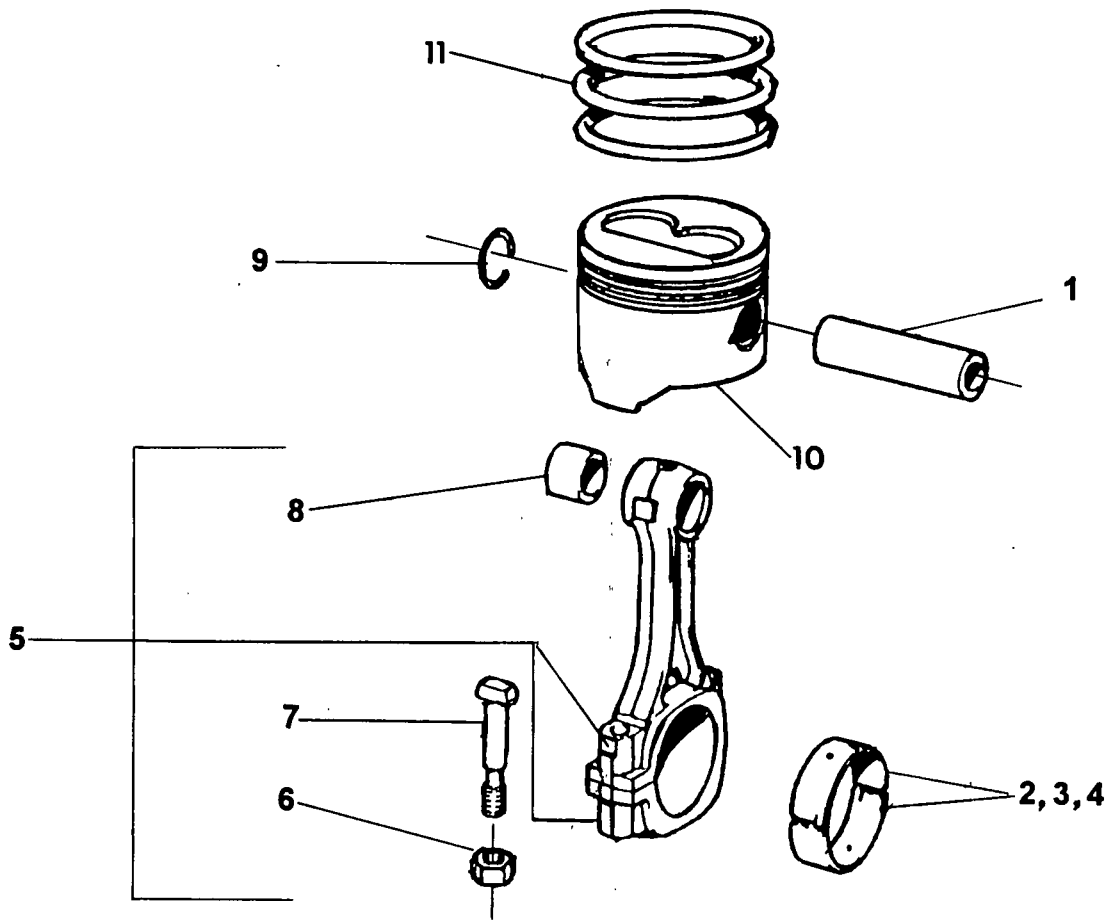

REF #	GENERAC #	DESCRIPTION	QTY
1	169-97390	PISTON PIN	4
2	170-97390	CONNECTING ROD BEARING (STD)	4
3	171-97390	CONNECTING ROD BEARING (0.10 mm U/S)	AR
4	172-97390	CONNECTING ROD BEARING (0.20 mm U/S)	AR
5	173-97390	CONNECTING ROD	4
6	174-97390	NUT	8
7	175-97390	CONNECTING ROD BOLT	8
8	176-97390	BUSHING	4
9	177-97390	LOCK RING	4
10	178-97390A	PISTON A-1 (STD SMALL PIN)	AR
	178-97390B	PISTON A-2 (STD LARGE PIN)	AR
	178-97390C	PISTON B-1 (STD+10 MICRONS)	AR
	178-97390D	PISTON B-2 (STD+10 MICRONS)	AR
	178-97390E	PISTON C-1 (B-1 +10 MICRONS)	AR
	178-97390F	PISTON C-2 (B-2 +10 MICRONS)	AR
	178-97390G	PISTON D-1 (C-1 +10 MICRONS)	AR
	178-97390H	PISTON D-2 (C-2 +10 MICRONS)	AR
	178-97390J	PISTON E-1 (D-1 +10 MICRONS)	AR
	178-97390K	PISTON E-2 (D-2 +10 MICRONS)	AR
	178-97390L	PISTON A (0.1 mm O/S)	AR
	178-97390M	PISTON C (0.1 mm O/S)	AR
	178-97390N	PISTON E (0.1 mm O/S)	AR
11	178-97390P	PISTON (0.4 mm O/S)	AR
	179-97390	RINGS (STD A-E & 0.1 mm O/S)	4
	180-97390	RINGS (0.4 mm O/S)	AR

TIMING BELT AND GEARS

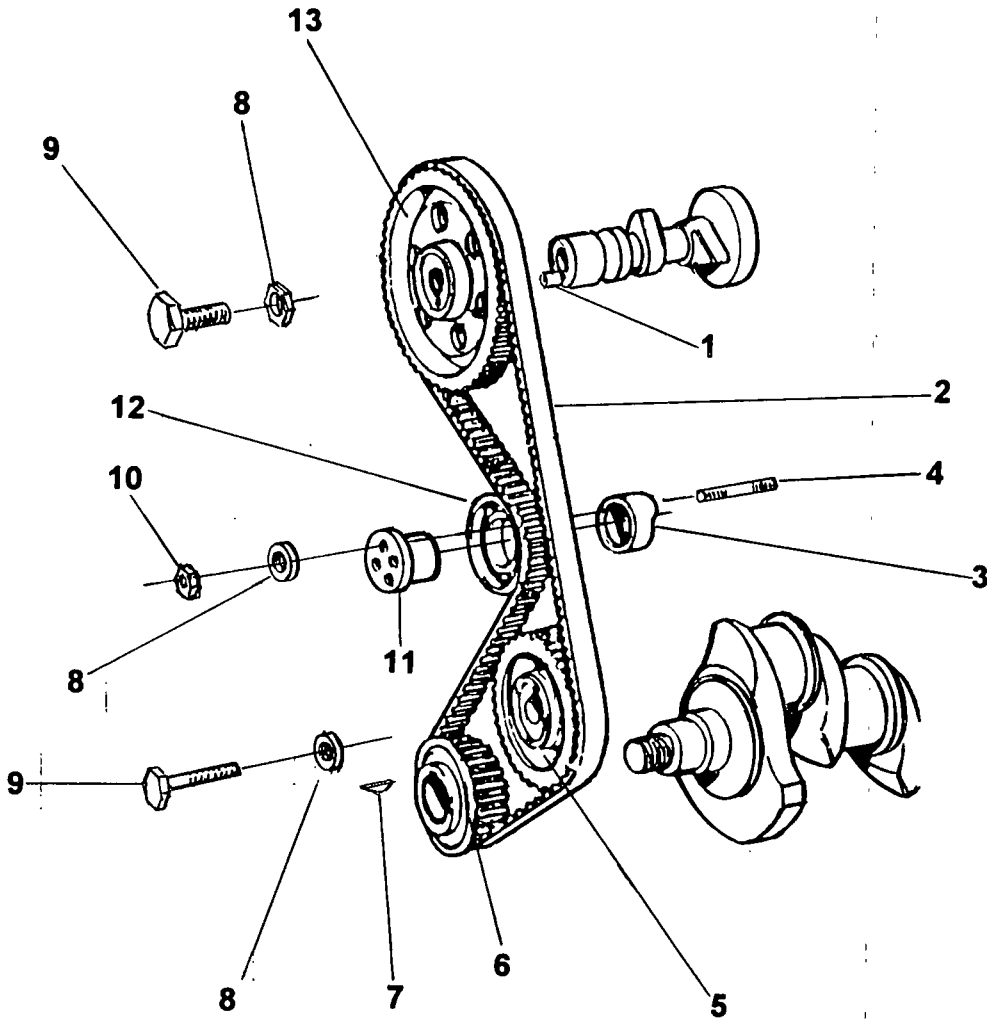

REF #	GENERAC #	DESCRIPTION	QTY
1	181-97390	PIN	1
2	182-97390	TIMING BELT	1
3	183-97390	SPACER	1
4	184-97390	STUD	2
5	185-97390	GEAR, OIL PUMP DRIVE	1
6	186-97390	DRIVING GEAR	1
7	187-97390	WOODRUFF KEY	1
8	188-97390	WASHER	3
9	189-97390	SCREW	2
10	190-97390	NUT	2
11	191-97390	HUB, IDLER	1
12	192-97390	BEARING, IDLER	1
13	193-97390	TIMING GEAR	1

TIMING BELT SHROUD

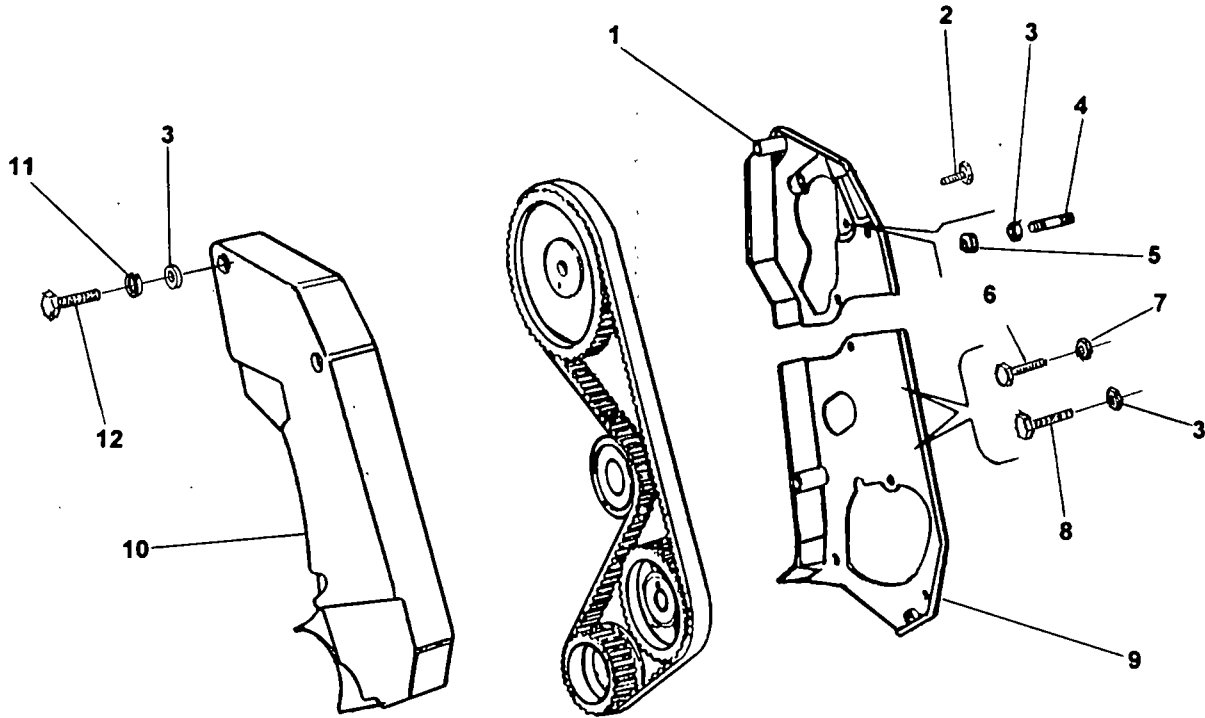

REF #	GENERAC #	DESCRIPTION	QTY
1	194-97390	UPPER SHROUD, TIMING BELT	1
2	195-97390	SCREW	1
3	196-97390	WASHER	3
4	144-97390	STUD	1
5	197-97390	NUT	2
6	198-97390	SCREW	1
7	122-97390	WASHER	1
8	199-97390	SCREW	1
9	200-97390	LOWER SHROUD, TIMING COVER	1
10	201-97390	OUTER SHROUD, TIMING COVER	1
11	131-97390	WASHER	1
12	202-97390	SCREW	1

VALVE TRAIN

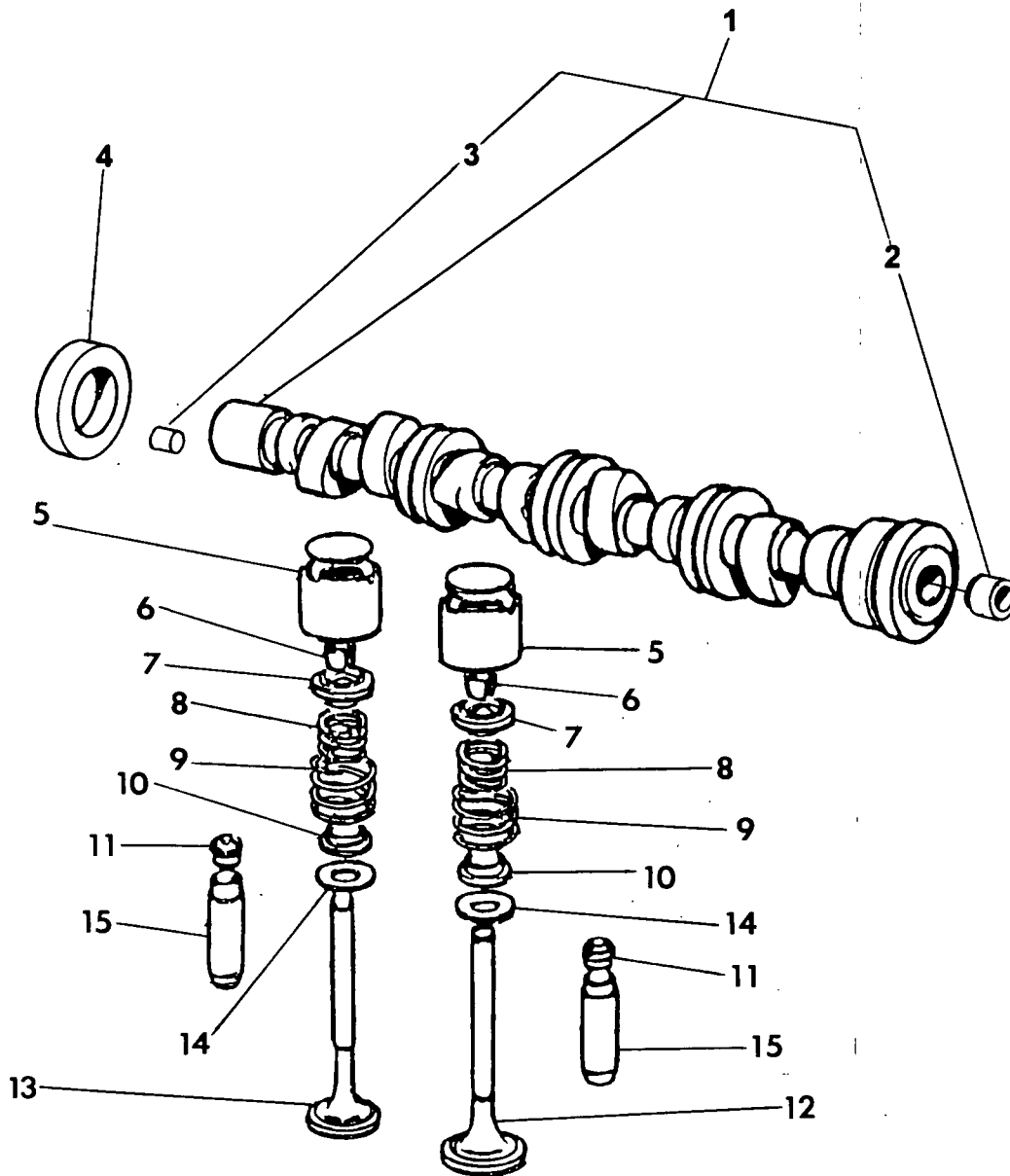

REF #	GENERAC #	DESCRIPTION	QTY
1	203-97390	CAMSHAFT	1
2	204-97390	DOWEL	1
3	181-97390	PIN	1
4	145-97390	CAMSHAFT OIL SEAL	1
5	205-97390	TAPPET	8
6	206-97390	LOCKING CONE	16
7	207-97390	CUP	8
8	208-97390	VALVE SPRING, INNER	8
9	209-97390	VALVE SPRING, OUTER	8
10	210-97390	CUP	8
11	211-97390	VALVE SEAL	8
12	212-97390	INTAKE VALVE	4
13	213-97390	EXHAUST VALVE	4
14	214-97390	WASHER	8
15	215-97390	VALVE GUIDE	8

VALVE SHIMS

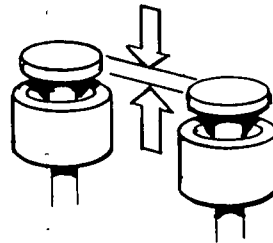
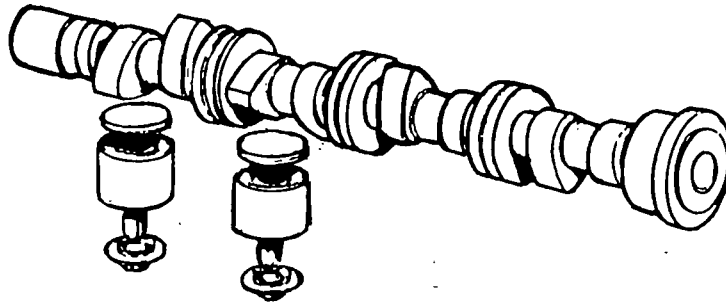

REF #	GENERAC #	DESCRIPTION	QTY
1	216-97390A	SHIM 3.25	AR
2	216-97390B	SHIM 3.30	AR
3	216-97390C	SHIM 3.35	AR
4	216-97390D	SHIM 3.40	AR
5	216-97390E	SHIM 3.45	AR
6	216-97390F	SHIM 3.50	AR
7	216-97390G	SHIM 3.55	AR
8	216-97390H	SHIM 3.60	AR
9	216-97390J	SHIM 3.65	AR
10	216-97390K	SHIM 3.70	AR
11	216-97390L	SHIM 3.75	AR
12	216-97390M	SHIM 3.80	AR
13	216-97390N	SHIM 3.85	AR
14	216-97390P	SHIM 3.90	AR
15	216-97390Q	SHIM 3.95	AR
16	216-97390R	SHIM 4.00	AR
17	216-97390S	SHIM 4.05	AR
18	216-97390T	SHIM 4.10	AR
19	216-97390U	SHIM 4.15	AR
20	216-97390V	SHIM 4.20	AR
21	216-97390W	SHIM 4.25	AR
22	216-97390X	SHIM 4.30	AR
23	216-97390Y	SHIM 4.35	AR
24	216-97390Z	SHIM 4.40	AR
25	217-97390A	SHIM 4.45	AR
26	217-97390B	SHIM 4.50	AR
27	217-97390C	SHIM 4.55	AR
28	217-97390D	SHIM 4.60	AR
29	217-97390E	SHIM 4.65	AR
30	217-97390F	SHIM 4.70	AR

OIL PUMP AND FILTER

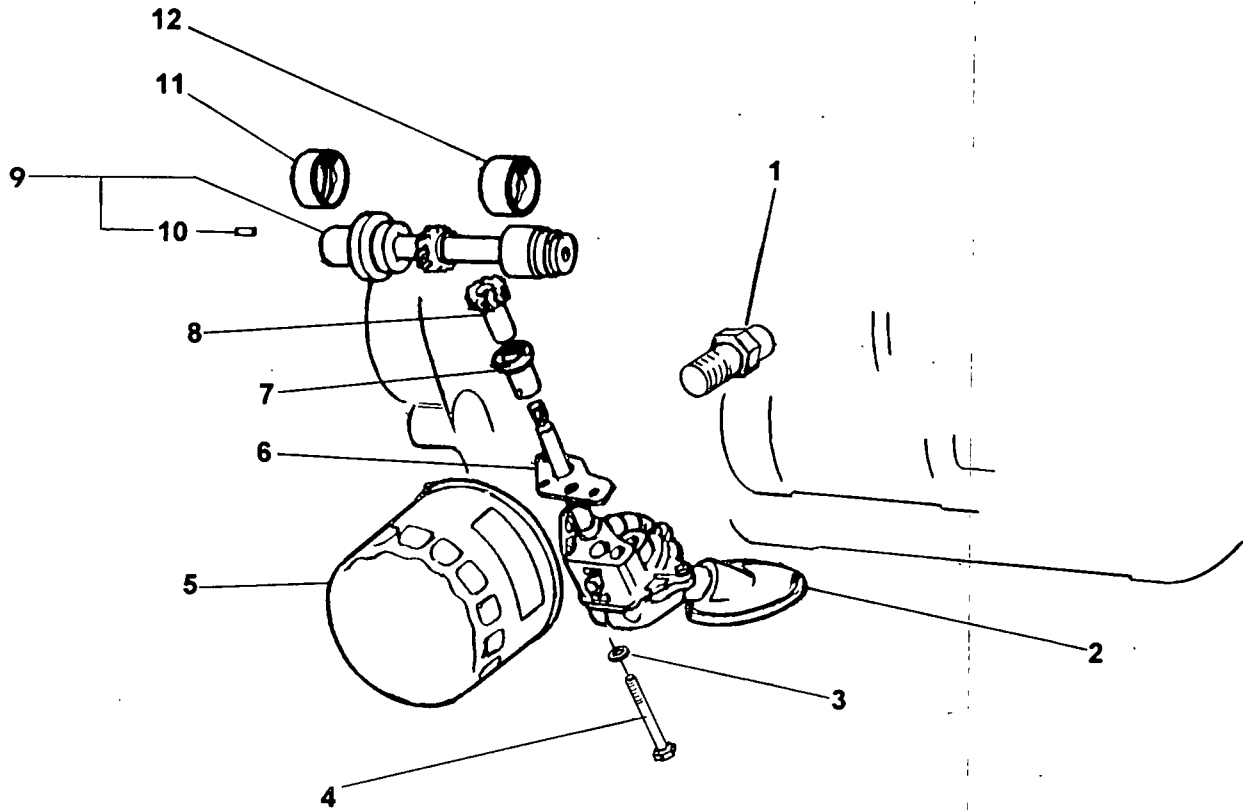

REF #	GENERAC #	DESCRIPTION	QTY
1	221-97390	CONNECTION	1
2	222-97390	OIL PUMP	1
3	121-97390	WASHER	1
4	223-97390	SCREW	1
5	99021	OIL FILTER	1
6	226-97390	BRACKET	1
7	227-97390	BUSHING	1
8	228-97390	OIL PUMP GEAR	1
9	229-97390	OIL PUMP DRIVE SHAFT	1
10	181-97390	PIN	1
11	231-97390	BUSHING	1
12	233-97390	BUSHING	1

COOLING SYSTEM

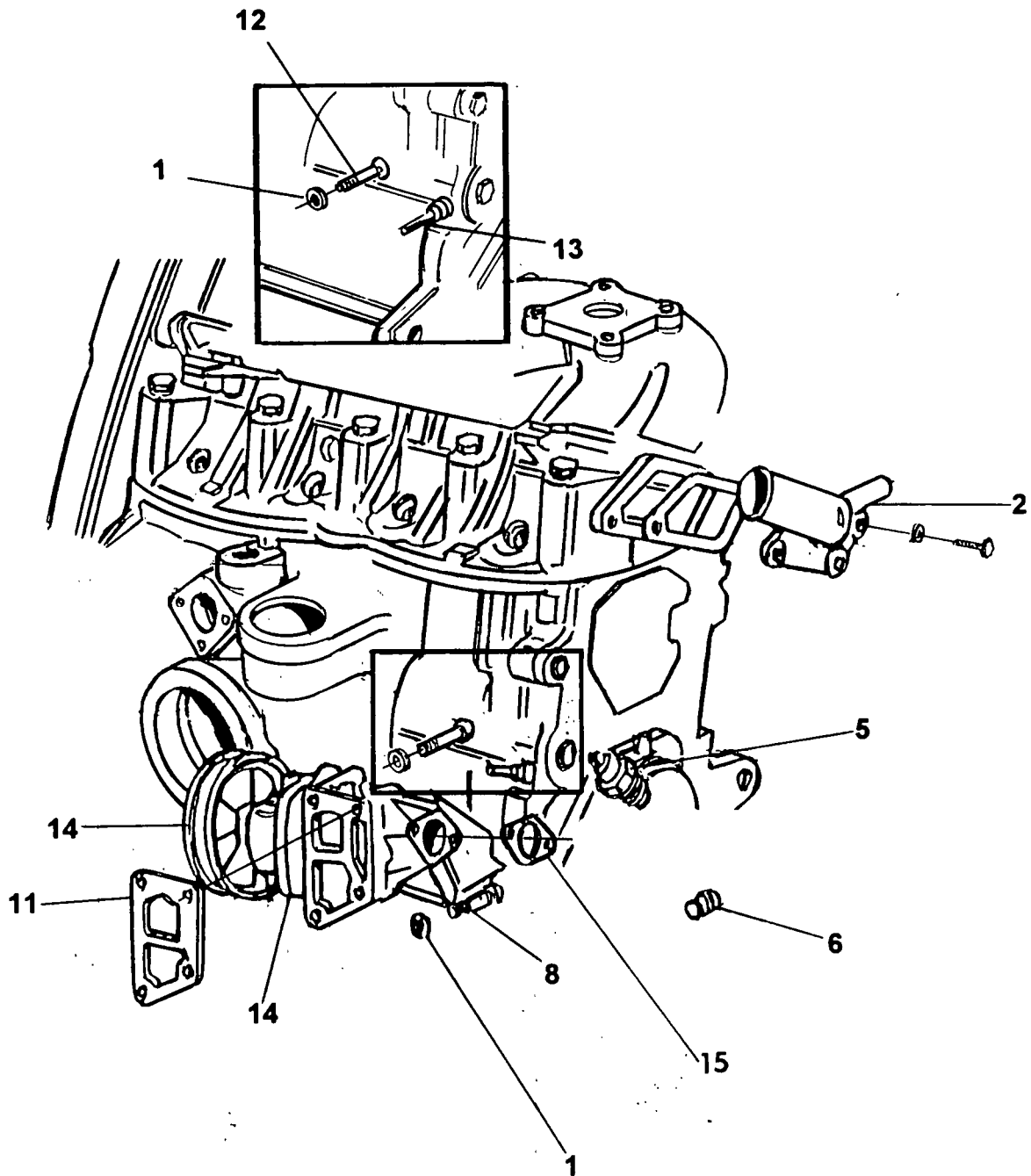

*(SEE ENGINE FINISH PARTS FOR THERMOSTAT SPACER, SCREWS, AND GASKET)

REF #	GENERAC #	DESCRIPTION	QTY
1	121-97390	WASHER	7
2	247-97390	THERMOSTAT*	1
6	251-97390	PLUG	1
8	254-97390	SCREW	3
11	261-97390	WATER PUMP GASKET	1
12	241-97390	SCREW	1
13	264-97390	SCREW AND WASHER	1
14	265-97390	WATER PUMP	1
15	99478	GASKET, WATER TUBE	1

ENGINE BREATHER

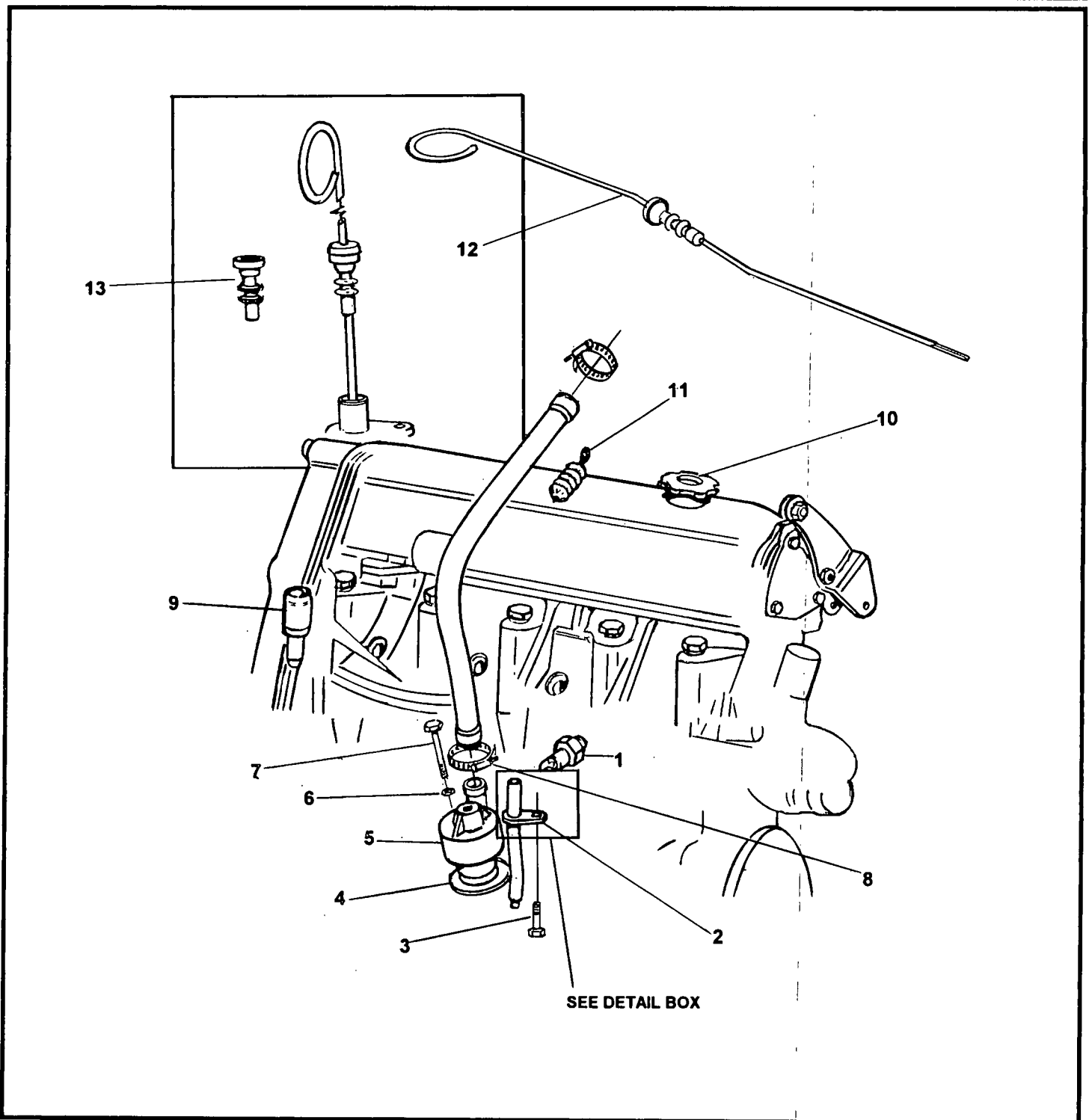

REF #	GENERAC #	DESCRIPTION	QTY
2	236-97390	HOLDER, OIL GAUGE	1
3	237-97390	SCREW	1
4	238-97390	WASHER	1
5	239-97390	BREATHER	1
6	240-97390	WASHER	1
7	241-97390	SCREW	1
8	242-97390	CLAMP	2
9	243-97390	JET	1
10	244-97390	CAP, OIL FILL	1
11	245-97390	FLAME TRAP	1
12	220-97390	OIL GAUGE	1

IGNITION SYSTEM

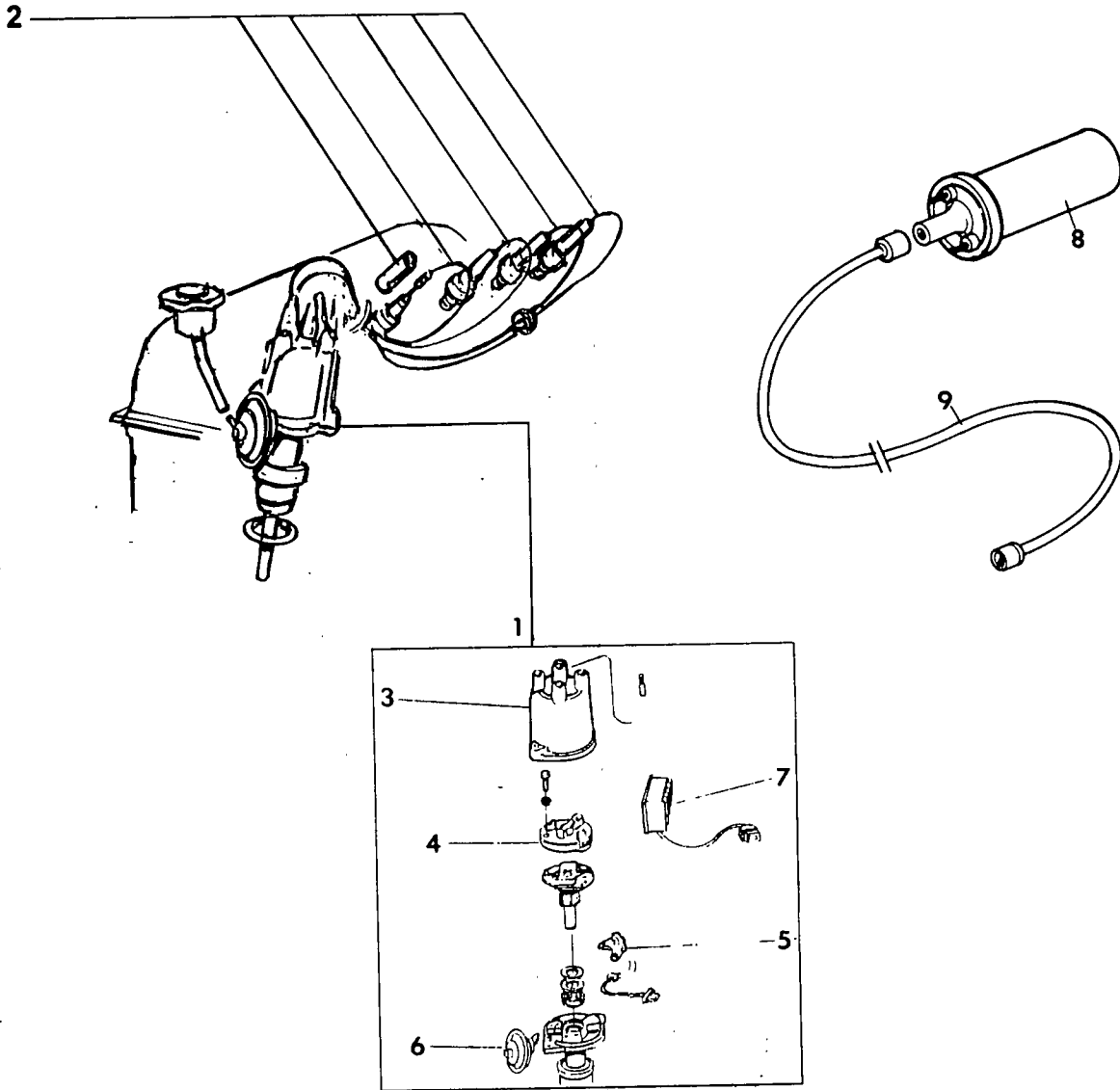

REF #	GENERAC #	DESCRIPTION	QTY
1	267-97390	DISTRIBUTOR ASS'Y	1
2	275-97390	SPARK PLUG WIRE	1
3	268-97390	DISTRIBUTOR CAP	1
4	269-97390	ROTOR	1
5	270-97390	PULSE COIL	1
6	271-97390	VACUUM UNIT	1
7	272-97390	ELECTRONIC MODULE	1
8	72557	COIL, IGNITION	1
9	98852	WIRE, IGNITION COIL	1

FUEL SYSTEM (nat. gas / LP vapor)

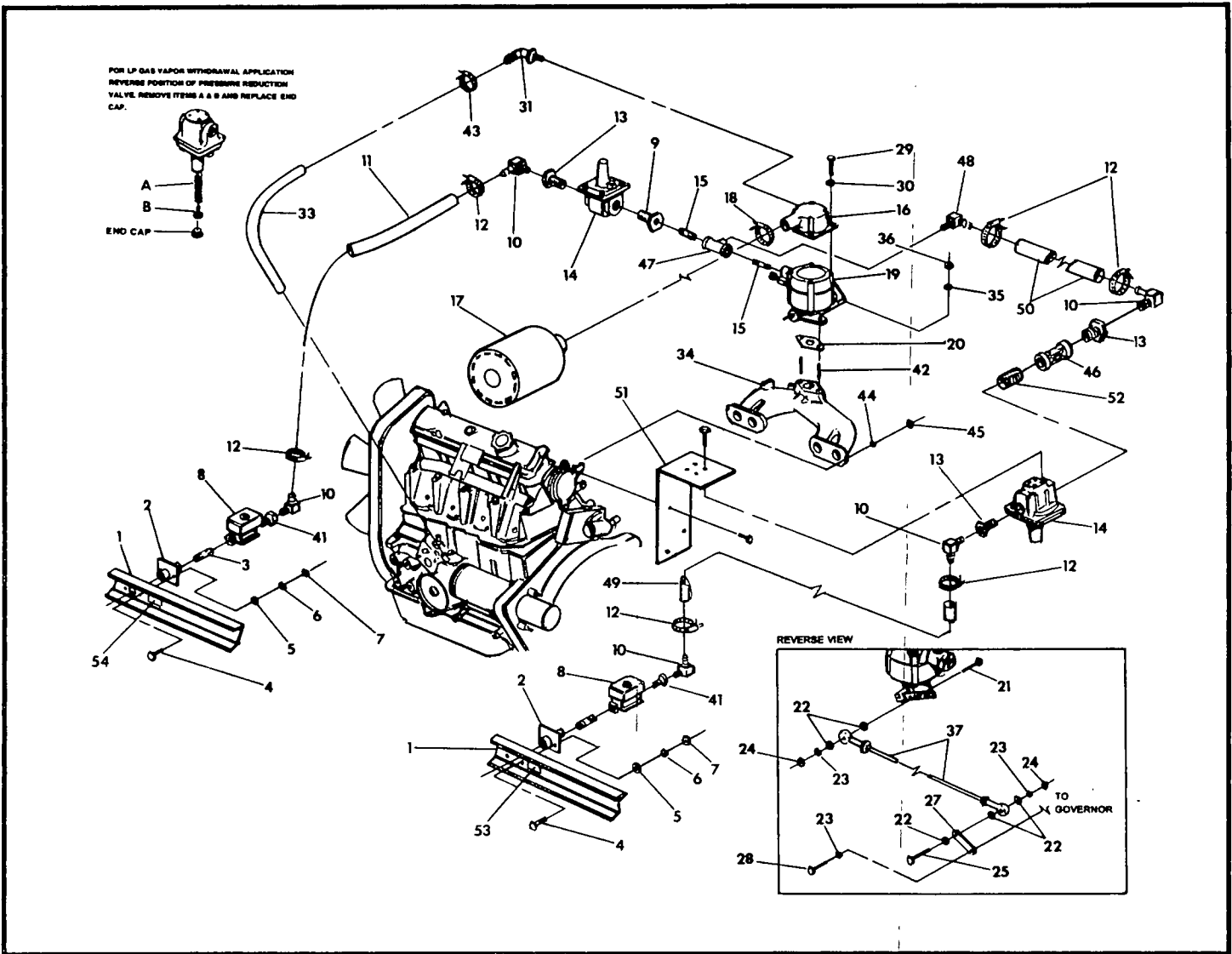

REF #	GENERAC #	DESCRIPTION	QTY
1	97341	BASE, MOUNTING	1
2	75580	FLANGE, FUEL INLET	2
3	26915	NIPPLE, 3/4" NPT	2
4	39253	CAP SCREW, HEX HEAD, M8 - 1.25 X 20MM	4
5	22145	WASHER, FLAT M8	4
6	22129	WASHER, LOCK M8	4
7	45771	NUT, HEX M8-1.25	4
8	43768A	SOLENOID, VALVE	2
9	61909	BUSHING, RED 1" - 3/8"	1
10	59412	FITTING, BARBED 90° 3/4" NPT X 5/8"	5
11	59194	HOSE, 5/8" I.D. X 36" LONG	36"
12	57823	CLAMP, HOSE #10	6
13	26577	RED BUSHING, 1" - 3/4	3
14	55944	VALVE, PRESSURE	2
15	35467	NIPPLE, PIPE 3/8" NPT X 1" CLOSE	2
16	98658	ADAPTER, AIR CLEANER	1
17	73912	CLEANER, AIR	1
18	35685	CLAMP, HOSE	1
19	59403	CARBURETOR	1
20	59401	GASKET, CARBURETOR	1
21	45757	M6 X 25 HEX HEAD CAP SCREW	1
22	49811	M6 FLAT WASHER	5
23	22097	M6 LOCK WASHER	3
24	49813	M6 HEX NUT	2
25	74095	M6 X 60 HEX HEAD CAP SCREW	1
27	98800	ARM, GOVERNOR	1

FUEL SYSTEM (nat. gas / LP vapor)

REF #	GENERAC #	DESCRIPTION	QTY
28	98859	HEX HEAD CAP SCREW 1/4" - 28 X 1" LONG	1
29	76011	PHILLIPS ROUND HEAD MACH. SCREW #10-24 X 1/2"	4
30	22152	WASHER, LOCK #10	4
31	98704	FITTING, BARBED 90° 3/4 X 1/2 NPT	1
33	50968	HOSE	26"
34	97636	INTAKE MANIFOLD	1
35	22129	5/16" LOCK WASHER	1
36	22259	5/16" HEX NUT	1
37	98321	CARB LINKAGE ASS'Y	1
41	40841	BUSHING, 3/4"-1/2"	2
42	28717	STUD 5/16"-18 X 1-1/2" LONG	2
44	22129	M8 LOCK WASHER	4
45	45771	M8 HEX NUT	4
46	60428	VALVE, AUX. ADJUST	1
47	27738	PIPE, TEE- 3/8" NPT	1
48	34339	BARBED 90° 3/8" NPT X 5/8"	1
49	59194	HOSE 5/8" I.D.	24"
50	59194	HOSE 5/8" I.D.	12"
51	97305	BRACKET, PRESSURE VALVE	1
52	25438	CLOSE NIPPLE, 1" NPT	1
53	50280	DECAL, LP GAS FUEL INLET	1
54	50279	DECAL, NATURAL GAS FUEL INLET	1

FUEL SYSTEM (natural gas)

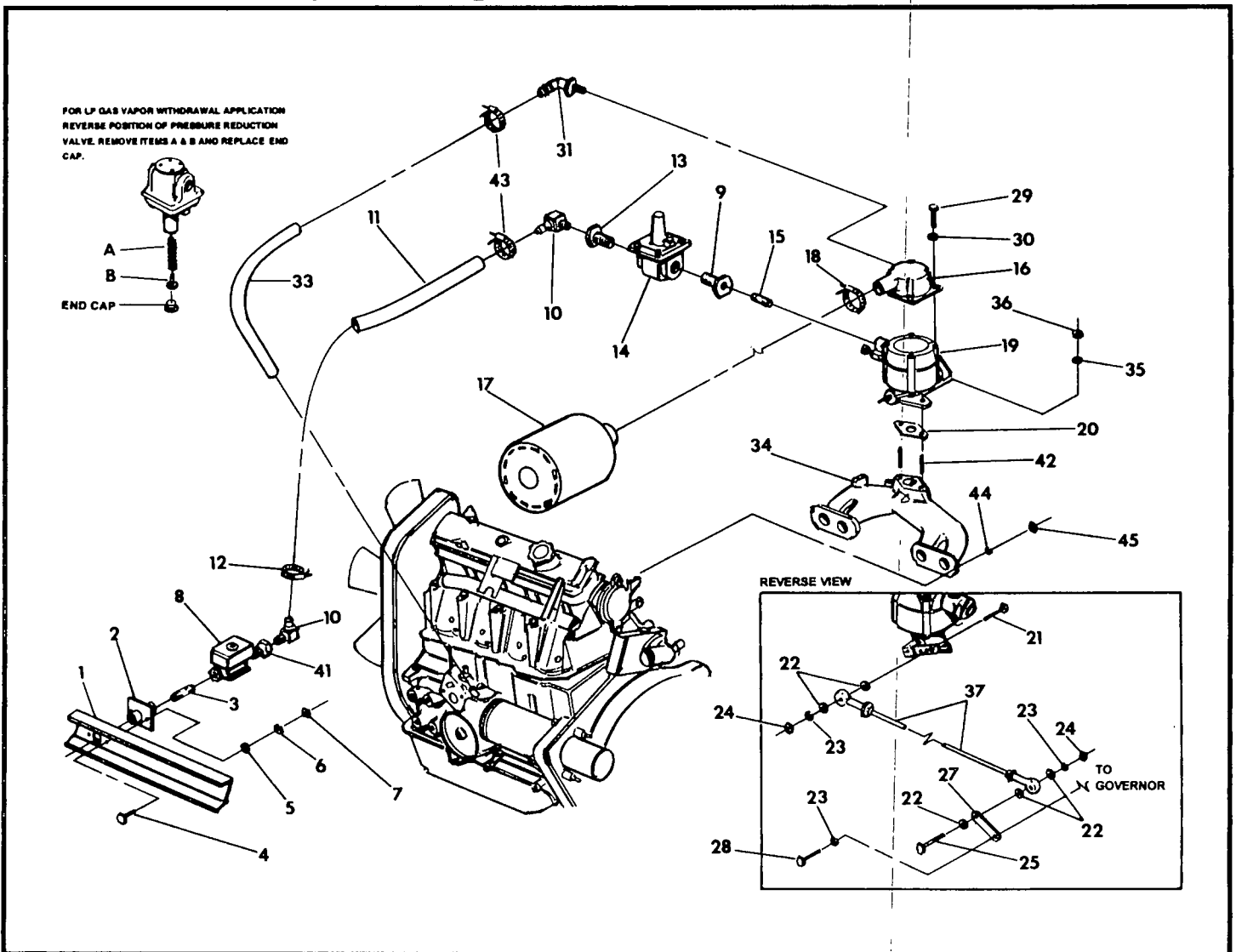

REF #	GENERAC #	DESCRIPTION	QTY
1	97341	BASE, MOUNTING	1
2	75580	FLANGE, FUEL INLET	1
3	26915	NIPPLE, 3/4" NPT	1
4	39253	HEX HEAD CAP SCREW, M8-1.25 X 20MM	2
5	22145	WASHER, FLAT M8	2
6	22129	WASHER, LOCK M8	2
7	45771	NUT, HEX M8-1.25	2
8	43768A	SOLENOID, VALVE	1
9	61909	BUSHING, RED 1" - 3/8"	1
10	59412	FITTING, BARBED 90° 3/4" NPT X 5/8"	2
11	59194	HOSE, 5/8" I.D. X 36" LONG	36"
12	57823	CLAMP, HOSE #10	2
13	26577	RED BUSHING, 1" - 3/4	1
14	55944	VALVE, PRESSURE	1
15	35467	NIPPLE, PIPE 3/8" NPT X 1" CLOSE	1
16	98658	ADAPTER, AIR CLEANER	1
17	73912	CLEANER, AIR	1
18	35685	CLAMP, HOSE	1
19	59403	CARBURETOR	1
20	59401	GASKET, CARBURETOR	1
21	45757	M6 X 25 HEX HEAD CAP SCREW	1
22	49811	M6 FLAT WASHER	5
23	22097	M6 LOCK WASHER	3
24	49813	M6 HEX NUT	2
25	74095	M6 X 60 HEX HEAD CAP SCREW	1
27	98800	ARM, GOVERNOR	1

FUEL SYSTEM (natural gas)

REF #	GENERAC #	DESCRIPTION	QTY
28	98859	HEX HEAD CAP SCREW 1/4" - 28 X 1" LONG	1
29	76011	PHILLIPS ROUND HEAD MACH. SCREW #10-24 X 1/2"	4
30	22152	WASHER, LOCK #10	4
31	98704	FITTING, BARBED 90° 3/4 X 1/2 NPT	1
33	50968	HOSE	26"
34	97636	INTAKE MANIFOLD	1
35	22129	5/16" LOCKWASHER	1
36	22259	5/16" HEX NUT	1
37	98321	CARB LINKAGE ASS'Y	1
41	40841	BUSHING, 3/4"-1/2"	1
42	28717	STUD 5/16"-18 X 1-1/2" LONG	2
43	35473	HOSE CLAMP #2	2
44	22129	M8 LOCKWASHER	4
45	45771	M8 HEX NUT	4

FUEL SYSTEM (LP liquid carburetor)

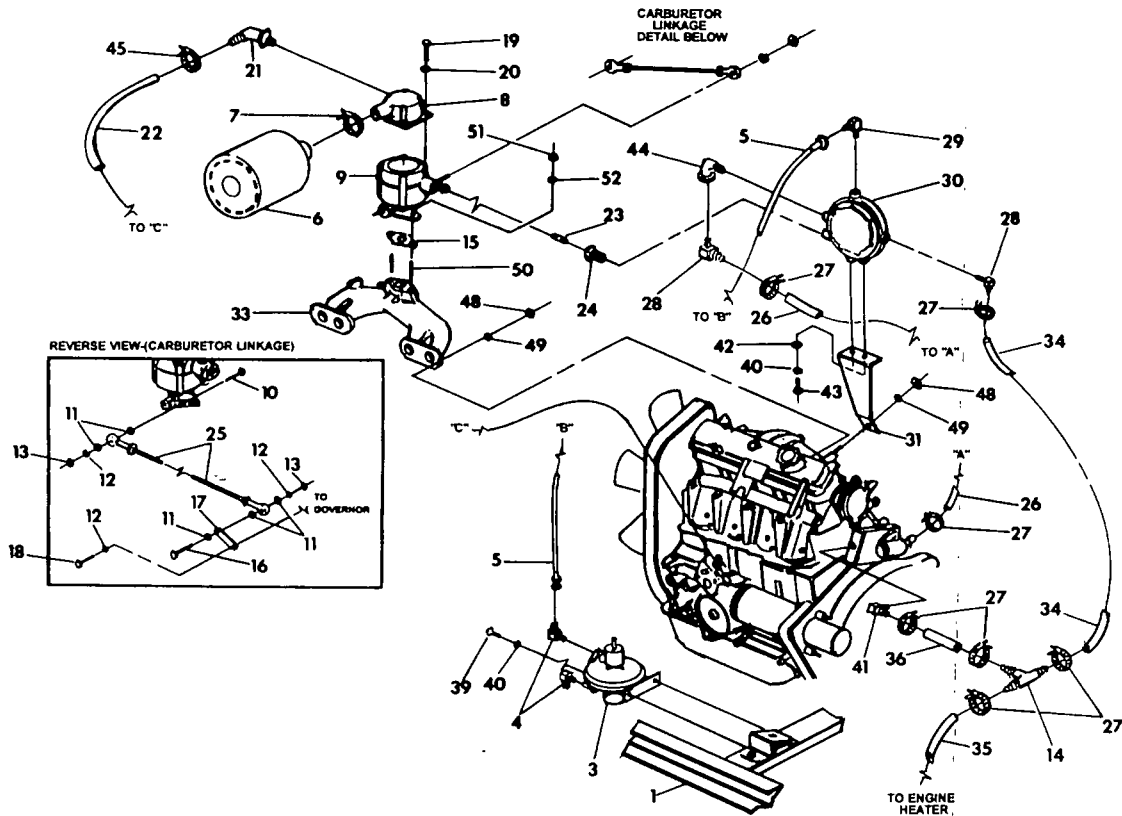

REF #	GENERAC #	DESCRIPTION	QTY
1	97341	MOUNTING BASE	1
3	49198	SOLENOID, FUEL SHUT- OFF	1
4	49663	FITTING, 90° BRASS-1/4" NPT	2
5	61903F	FUEL LINE, LPG - 35" LONG	35"
6	73912	CLEANER, AIR	1
7	35685	CLAMP, HOSE #28	1
8	98658	ADAPTER, AIR CLEANER	1
9	59403	CARBURETOR	1
10	45757	M6 X 25 HEX HEAD CAP SCREW	1
11	49811	M6 FLAT WASHER	5
12	22097	M6 LOCK WASHER	3
13	49813	M6 HEX NUT	2
14	63242	BARBED WYE -5/8" HOSE	1
15	59401	GASKET, CARBURETOR	1
16	74095	M6 X 60 HEX HEAD CAP SCREW	1
17	98800	ARM, GOVERNOR	1
18	98859	HEX HEAD CAP SCREW, 1/4"-28 X 1" LONG	1
19	76011	PHILLIPS ROUND HEAD MACH. SCREW #10-24 X 1/2"	4
20	22152	LOCK WASHER #10	4
21	98704	FITTING, BARBED 90° 3/4" X 1/2" NPT	1
22	50968	HOSE 3/4" I.D.	26"
23	35467	NIPPLE, PIPE 3/8" NPT X CLOSE	1
24	61909	BUSHING, REDUCER 1"-3/8"	1
25	98321	CARB. LINKAGE ASS'Y	1
26	50967	HOSE, 5/8" I.D. X 14" LONG	1
27	57823	CLAMP, HOSE #10	8
28	34339	FITTING, 90° ELBOW- 3/8" NPT X 5/8"	2
29	46964	ELBOW, BRASS- ST. 1/4" NPT	1
30	51358	VAPORIZER, LP GAS	1
31	98934	BRACKET, VAPORIZER SUPPORT	1
33	97636	MANIFOLD, INTAKE	1
34	50967	HOSE- 5/8" I.D.	17"

FUEL SYSTEM (LP liquid carburetor)

REF #	GENERAC #	DESCRIPTION	QTY
35	50967	HOSE- 5/8" I.D.	8"
36	50967	HOSE- 5/8" I.D.	9"
39	45757	HEX HEAD CAP SCREW, M6- X MM	2
40	22097	LOCK WASHER M6	4
41	34339	BARBED FITTING, 90° 3/8" NPT X 5/8" HOSE	1
42	22473	FLAT WASHER M6	2
43	22287	HEX HEAD CAP SCREW, 1/4"-20 X .75" LONG	2
44	26924	STREET ELBOW-3/8" NPT	1
45	35473	CLAMP, HOSE #12	1
48	22129	M8 LOCK WASHER	5
49	45771	M8 HEX NUT	5
50	28717	STUD 5/16"-18 X 1-1/2" LONG	2
51	22259	5/16" HEX NUT	2
52	22129	5/16" LOCK WASHER	2

ENGINE FINISH PARTS (mechanical governor units)

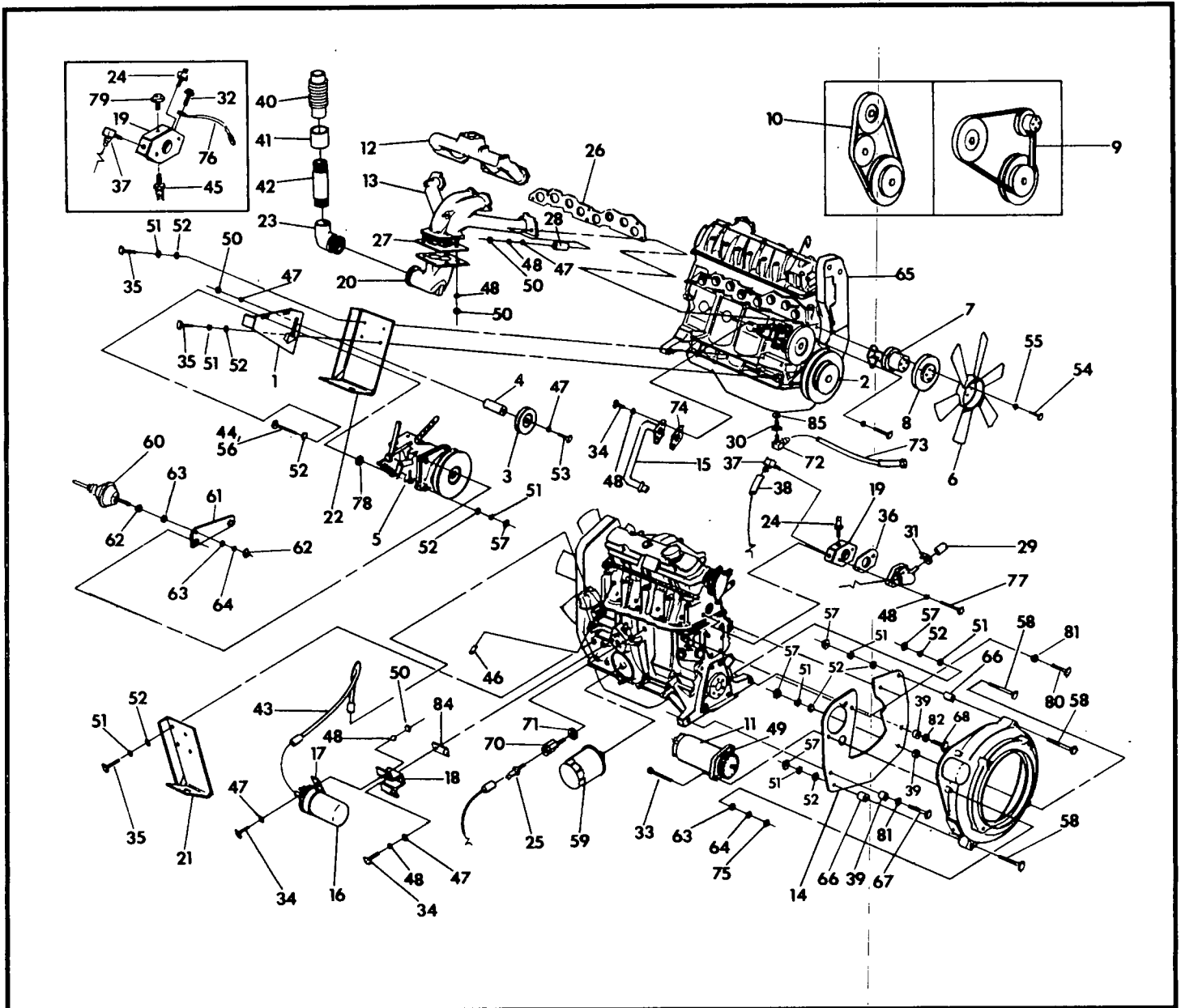

REF #	GENERAC #	DESCRIPTION	QTY
1	98064	GOVERNOR BRACKET	1
2	97280	CRANK PULLEY	1
3	43604	IDLER PULLEY	1
4	97666	IDLER PULLEY SPACER	1
5	98966	MECH. GOVERNOR ASS'Y (1800 RPM)	1
	98996	MECH. GOVERNOR ASS'Y (3600 RPM)	1
6	75613	FAN	1
7	97406	FAN ASS'Y (1800 RPM)	1
	97408	FAN ASS'Y (3600 RPM)	1
8	52230	3600 RPM FAN PULLEY	1
9	39379	BELT, FAN	1
10	79199	BELT, WATER PUMP	1
11	70954	STARTER	1
12	97636	INTAKE MANIFOLD	1
13	98133	EXHAUST MANIFOLD	1
14	97221	ENGINE PLATE	1
15	98070	WATER INLET TUBE	1
16	72557	COIL, IGNITION	1
17	74816	IGNITION COIL BRACKET	1
18	97632	COIL COVER BRACKET	1
19	98509	THERMOSTAT SPACER	1

ENGINE FINISH PARTS (mechanical governor units)

REF #	GENERAC #	DESCRIPTION	QTY
20	98057	EXHAUST ADAPTER	1
21	98068	MOTOR MOUNT, LEFT	1
22	98067	MOTOR MOUNT, RIGHT	1
23	62091	1-1/2" STREET ELBOW	1
24	57522	LOW LEVEL SENSOR	1
25	50108	SWITCH, OIL PRESSURE	1
26	97402	INTAKE / EXHAUST GASKET	2
27	98690	EXHAUST ADAPTER GASKET	1
28	22625B	EXHAUST SPACER	2
29	77996	BY-PASS CAP	1
30	55809	OIL DRAIN ADAPTER	1
31	35473	HOSE CLAMP #12	4
32	46852	TAPTITE 10-32 X 1/4"	1
33	99379	SOCKET HEAD CAP SCREW, 5/16"-18 X 3" LONG	2
34	39253	HEX HEAD CAP SCREW M8-1.25 X 20	5
35	52213	HEX HEAD CAP SCREW M10-1.25 X 20	7
36	98907	THERMOSTAT GASKET	2
37	34339	BARBED FITTING 3/8" NPT ELBOW	1
38	50967	HEATER HOSE, 5/8"	3FT.
39	97981	ENGINE PLATE SPACER	2
40	75546	FLEX EXHAUST	1
41	67729	PIPE COUPLING, 1-1/2"	1
42	67730	PIPE NIPPLE 1-1/2" X 7-1/2" LONG	1
43	98852	IGNITION COIL WIRE	1
44**	49812	HEX HEAD CAP SCREW M10-1.50 X 55	2
45#	53667	TEMPERATURE SENSOR	1
46	99020	SOCKET HEAD CAP SCREW M10-1.25 X 10	1
47	22145	FLAT WASHER M8	10
48	22129	LOCK WASHER M8	15
49	97220	ADAPTER STARTER	1
50	45771	HEX NUT M8-1.25	9
51	46526	LOCK WASHER M10	10
52	49809	FLAT WASHER M10	10
53	52203	HEX HEAD CAP SCREW M8-1.25 X 70	1
54	42568	HEX HEAD CAP SCREW M6-1.00 X 20	6
55	70005	LOCK WASHER M6	6
56*	64416	HEX HEAD CAP SCREW M-10-1.50 X 45	2
57	45772	HEX NUT M10-1.50	6
58	51735	HEX HEAD CAP SCREW M10-1.50 X 70	2
59	99021	FILTER, OIL	1
60**	57406	DASH POT	1
61**	75866A	BRACKET, DASH POT	1
62**	31596	HEX NUT 5/16"-24	2
63	22145	FLAT WASHER 5/16"	4
64	22129	LOCK WASHER 5/16"	3
65	97390	ENGINE, 1.6L	1
66	70901	DOWEL, SLEEVE	2
67	75672	HEX HEAD CAP SCREW M12-1.25 X 40	1
68	81816	HEX HEAD CAP SCREW M12-1.75 X 55	1
69	56768	HEX HEAD CAP SCREW M10-1.50 X 90	1
70	75797	ADAPTER	1
71	57772	WASHER, NYLON	1
72	43790	3/8" BARBED ELBOW	1
73	69860C	OIL DRAIN HOSE ASS'Y	1
74	99478	GASKET, WATER TUBE	1
75	22259	HEX NUT 5/16"-18	2
76	97308	WIRE, THERMOSTAT GROUND	1
77	52265	HEX HEAD CAP SCREW M8-1.25 X 65	2
78**	59526	SPACER, GOVERNOR	2
79	26925	PIPE PLUG 3/8" NPT	1
80	68485	HEX HEAD CAP SCREW M12-1.25 X 20	2
81	51769	LOCK WASHER M12	4
82	49808	FLAT WASHER M12	2
83	69918	HEX NUT M12-1.25	1
84	99512	COIL COVER GASKET	1
85	97352	NYLON WASHER	1

* 3600 RPM UNITS ONLY

** 1800 RPM UNITS ONLY

PANEL B & C OPTIONS ONLY

ENGINE FINISH PARTS (electronic governor units)

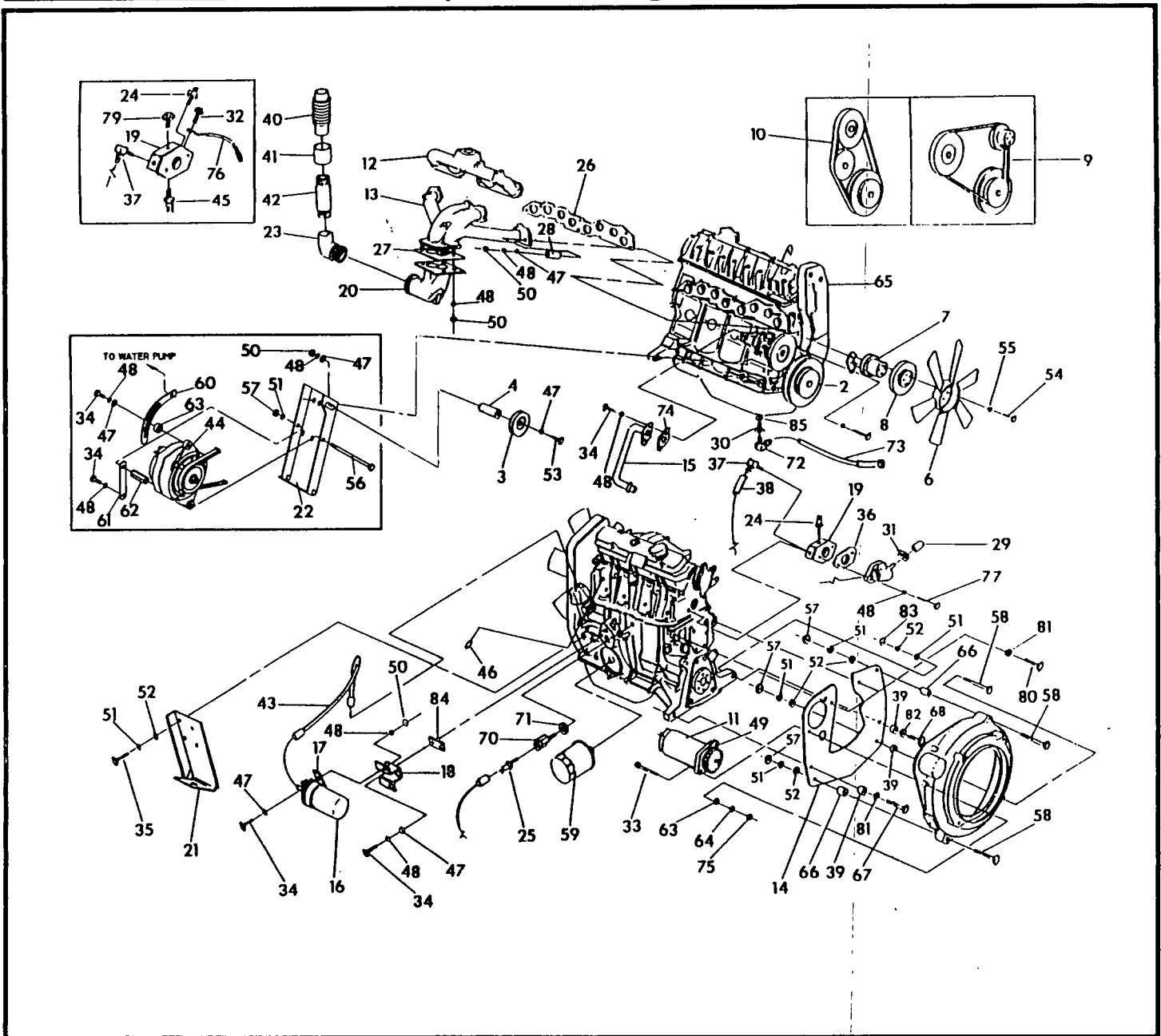

REF #	GENERAC #	DESCRIPTION	QTY
2	97280	CRANK PULLEY	1
3	43604	IDLER PULLEY	1
4	20534	IDLER PULLEY SPACER	1
6	75613	FAN	1
7	97406	FAN ASS'Y (1800 RPM)	1
	97408	FAN ASS'Y (3600 RPM)	1
8	52230	3600 RPM FAN PULLEY	1
9	20439	BELT, FAN (3600 RPM)	1
	20621	BELT, FAN (1800 RPM)	1
10	75130	BELT, WATER PUMP	1
11	70954	STARTER	1
12	97636	INTAKE MANIFOLD	1
13	98133	EXHAUST MANIFOLD	1
14	97221	ENGINE PLATE	2
15	98070	WATER INLET TUBE	1
16	72557	COIL, IGNITION	1
17	74816	IGNITION COIL BRACKET	1
18	97632	COIL COVER BRACKET	1
19	98509	THERMOSTAT SPACER	1

ENGINE FINISH PARTS (electronic governor units)

REF #	GENERAC #	DESCRIPTION	QTY
20	98057	EXHAUST ADAPTER	1
21	98068	MOTOR MOUNT, LEFT	1
22	98284	MOTOR MOUNT, RIGHT	1
23	77437	1-1/2" STREET ELBOW	1
24	57522	LOW LEVEL SENSOR	1
25	60108	SWITCH, OIL PRESSURE	1
26	97402	INTAKE / EXHAUST GASKET	2
27	98690	EXHAUST ADAPTER GASKET	1
28	22625B	EXHAUST SPACER	2
29	77996	BY-PASS CAP	1
30	55809	OIL DRAIN ADAPTER	1
31	35473	HOSE CLAMP #12	4
32	46852	TAPTITE 10-32 X 1/4"	1
33	99379	SOCKET HEAD CAP SCREW 5/16"-18 X 3" LONG	2
34	39253	HEX HEAD CAP SCREW M8-1.25 X 20	6
35	52213	HEX HEAD CAP SCREW M10-1.25 X 20	7
36	98907	THERMOSTAT GASKET	2
37	34339	BARBED FITTING 3/8" NPT ELBOW	1
38	50967	HEATER HOSE 5/8"	3FT.
39	97981	ENGINE PLATE SPACER	2
40	75546	FLEX EXHAUST	1
41	67729	PIPE COUPLING 1-1/2"	1
42	67730	PIPE NIPPLE 1-1/2" X 7-1/2" LONG	1
43	98852	IGNITION COIL WIRE	1
44	50618	ALTERNATOR	1
45#	53667	TEMPERATURE SENSOR	1
46	99020	SOCKET HEAD CAP SCREW M10-1.25 X 10	1
47	22145	FLAT WASHER M8	10
48	22129	LOCK WASHER M8	16
49	97220	ADAPTER, STARTER	1
50	45771	HEX NUT M8-1.25	9
51	46526	LOCK WASHER M10	9
52	49809	FLAT WASHER M10	9
53	52203	HEX HEAD CAP SCREW M8-1.25 x 70	1
54	42568	HEX HEAD CAP SCREW M6-1.00 X 20	6
55	70005	LOCK WASHER M6	6
56	20435	HEX HEAD CAP SCREW M10-1.50 X 140	1
57	45772	HEX NUT M10-1.50	5
58	51735	HEX HEAD CAP SCREW M10-1.50 X 70	2
59	99021	FILTER, OIL	1
60	20048	BRACKET, TENSIONER	1
61	20460	BRACKET, ALTERNATOR SUPPORT	1
62	56472	ALTERNATOR SPACER	1
63	59526	TENSIONER SPACER	1
65	97390	ENGINE, 1.6L	1
66	70901	DOWEL, SLEEVE	2
67	75672	HEX HEAD CAP SCREW M12-1.25 X 40	1
68	81816	HEX HEAD CAP SCREW M12-1.75 X 55	1
69	56768	HEX HEAD CAP SCREW M10-1.50 X 90	1
70	75797	ADAPTER	1
71	57772	WASHER, NYLON	1
72	43790	3/8" BARBED ELBOW	1
73	69860C	OIL DRAIN HOSE ASS'Y	1
74	99478	GASKET, WATER TUBE	1
75	22259	HEX NUT 5/16"-18	2
76	97308	WIRE, THERMOSTAT GROUND	1
77	52265	HEX HEAD CAP SCREW M8-1.25 X 65	2
79	26925	PIPE PLUG 3/8" NPT	1
80	68485	HEX HEAD CAP SCREW M12-1.25 X 20	2
81	51769	LOCK WASHER M12	4
82	49808	FLAT WASHER M12	2
83	45773	HEX NUT M12-1.75	1
84	99512	COIL COVER GASKET	1
85	97352	NYLON WASHER	1

PANEL B & C OPTIONS ONLY

ELECTRONIC GOVERNOR

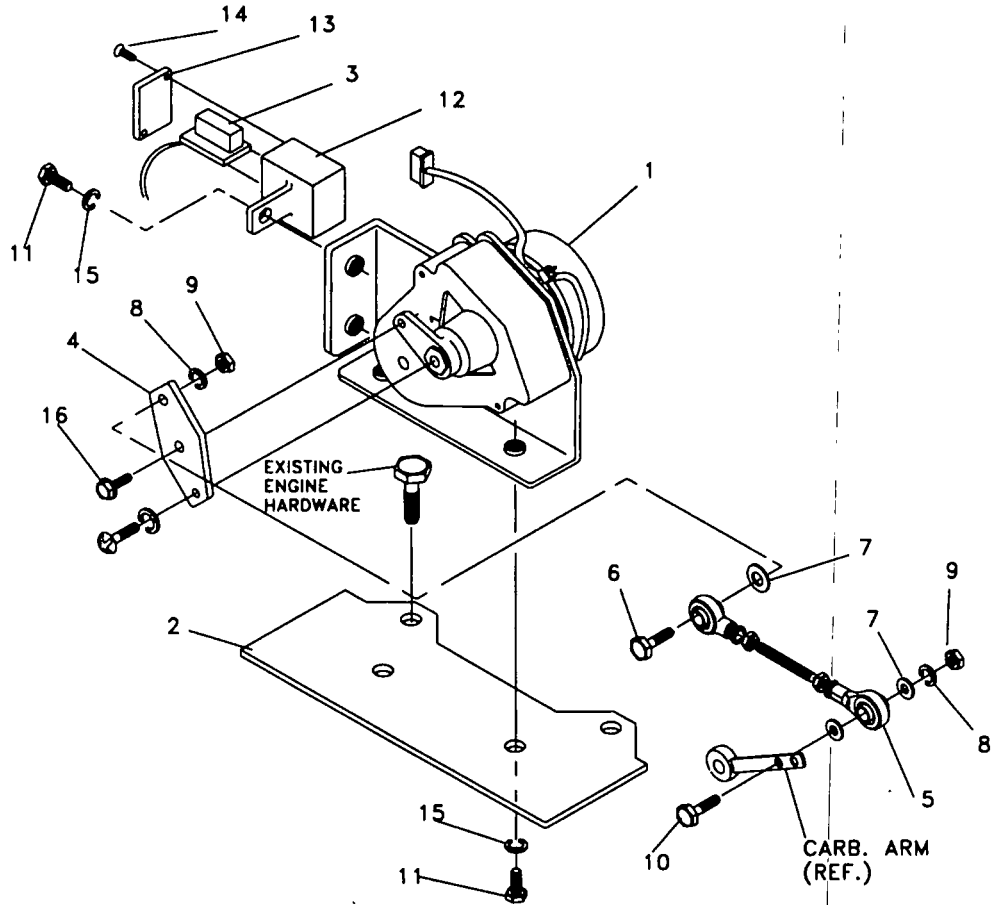

REF #	GENERAC #	DESCRIPTION	QTY
1	98290	STEPPER MOTOR ASS'Y	1
2	98276	BRACKET, MOTOR MOUNT	1
3	98958	CONNECTOR INTERFACE ASS'Y	1
4	98783	LEVER, STEPPER MOTOR	1
5	98275	CARB. LINKAGE ASS'Y	1
6	33138	HEX HEAD MACH. SCREW #10-32 X 5/8" LONG	1
7	23897	FLAT WASHER #10	3
8	22152	LOCK WASHER #10	2
9	22158	HEX NUT #10-32	2
10	33147	HEX HEAD MACH. SCREW #10-32 X 1" LONG	1
11	43146	HEX HEAD MACH. SCREW M6-1.0 X 10 LONG	3
12	98941A	HOUSING, CONNECTOR INTERFACE	1
13	98942A	COVER, INTERFACE HOUSING	1
14	98225	PHILLIPS HEAD MACH. SCREW #2 X 5/8" SELF TAP	2
15	22097	LOCK WASHER M6	3
16	64526	HEX HEAD MACH. SCREW #6-32 X 3/8" SELF TAP	1

